

PRODUCT MANUAL

ULTRA-STABLE HIGH PRECISION CURRENT TRANSDUCERS

- INTEGRATED BODY: DS, DQ, DM, DL, DT, DN, DW SERIES
- SEPARATE HEAD TRANSDUCER SYSTEMS: DR SERIES

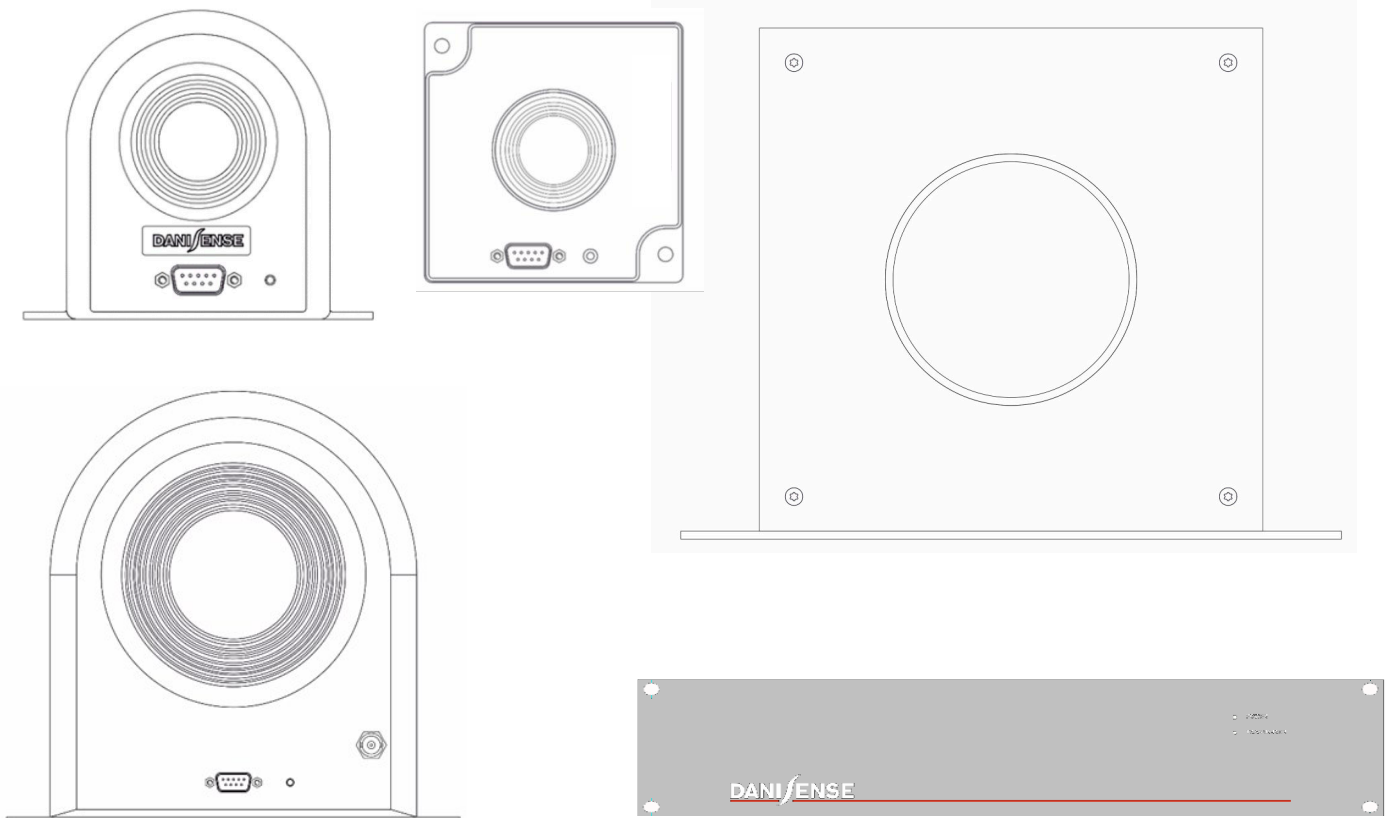

TABLE OF CONTENTS

1. NOTICE.....	3
1.1 Safety informations.....	3
1.2 Certifications.....	3
2. INTEGRATED BODY TRANSDUCERS (DS, DQ, DM, DL series).....	4
2.1 Introduction & overview.....	4
2.2 Description.....	5
2.3 Installation & Operation.....	6
2.3.1 Mounting instructions.....	6
2.3.1.1 Positive current flow.....	6
2.3.1.2 Fastening torques.....	6
2.3.2 Electrical connection instructions.....	7
2.3.2.1 Current output.....	7
2.3.2.1.1 Standard version.....	7
2.3.2.1.2 Calibration winding version.....	8
2.3.2.2 Voltage output.....	8
2.3.3 Power supplies interface units.....	9
2.3.3.1 Main features.....	9
2.3.3.2 Multi-channels power supplies interface DSSIU series....	9
2.3.3.3 Connection of calibration winding with DSSIU-6-1U (-V)..	10
2.3.3.4 Voltage output modules (VOM).....	11
2.3.3.5 DSSIU-6-1U-V current / voltage output cables.....	11
2.3.3.6 Noises immunity of voltage output versions.....	12
3. SEPARATE HEAD TRANSDUCER SYSTEMS (DR series).....	13
3.1 Introduction & overview.....	13
3.2 Description.....	13
3.3 Installation & Operation.....	14
3.3.1 Mounting instructions.....	14
3.3.1.1 Positive current flow.....	14
3.3.1.2 Mechanical fixations.....	14
3.3.2 Electrical connection instructions.....	15
3.3.2.1 Current output.....	15
3.3.2.2 Voltage output.....	16
3.3.2.3 Connection transducer head to control unit.....	16
4. ELECTRICAL CONSIDERATION.....	18
4.1 Common mode noises.....	18
4.2 Ground Loop Currents Consideration.....	19
4.2.1 Standard setup.....	19
4.2.2 Other problematic example of connection setup.....	21
4.2 Saturation behavior.....	22
4.3 Influence of the return conductor.....	23
4.4 Derating of external measuring resistor R_M	24
4.5 Frequency derating.....	24
4.6 Measuring large current with two transducers.....	25
4.7 Measuring small currents with multiple primary turns.....	25
4.8 Advanced Sensor Protection Circuit (ASPC).....	26
5. DEFINITION OF PARAMETERS.....	27
6. PRODUCT NAMING RULES.....	28

1. NOTICE

1.1 Safety information

The user must have read and understood this chapter before undertaking any action with the measuring device. For all information considered inadequate, please contact the manufacturer or your local representative.



- ⇒ Do not use the device in any manner not specified by the manufacturer.
- ⇒ Do not use the device if it is damaged. Please perform a prior visual inspection to detect possible breaks or damages.
- ⇒ Turn OFF all power sources before connecting - disconnecting the device.
- ⇒ Always use the device with the cables provided or in option.
- ⇒ Respect the pin assignment of the connector.
- ⇒ Respect INSULATION class of the device.
- ⇒ Ensure that the device's output is NOT open.
- ⇒ Device must be powered and ready (green LED lit) before turning ON the primary circuit. And in case of separate head transducer system, please:
 - ◆ Ensure that the sensing head is connected to the control rack
- ⇒ Ensure that there is NO current in the primary before turning on the device

CAUTION

- ⇒ This device is designed for indoor applications and the user must refer to the datasheet for the operating conditions.

1.2 Certification

The present products are designed in compliance with the CE and RoHS directives.



This device should not be placed in the general waste. It can be recycled.



2. INTEGRATED BODY TRANSDUCERS (DS, DQ, DM, DL, DN & DT series)

2.1 Introduction and overview

The DS, DQ, DM & DL series, ultra-stable and high precision current transducers are based on closed loop flux gate principle allowing to achieve ppm level accuracy, excellent linearity and stability versus time. The integration of the sensing head and the control electronics in a single housing allows a compact design. The following table shows the rated current range overview and model names.

Family name	Output type	Options	Rated primary current Arms						
			50A	100A	200A	300-400A	500-1000A	1200A	2000A
DS Series	Current	Standard	DS50ID		DS200ID	DS300ID DS400ID	DS600ID		
		Calibration Winding			DS200ID-CD100 DS200ID-CD1000		DS600ID-CD100		
	Voltage	Standard	DS50UB-1V DS50UB-10V		DS200UB-1V DS200UB-10V	DS300UB-1V DS300UB-10V DS400UB-1V DS400UB-10V	DS600UB-1V DS600UB-10V DS1000UB-10V		
DM Series	Current	Standard						DM1200ID	
		Calibration Windings						DM1200ID-CD3000	
	Voltage	Standard						DM1200UB-1V DM1200UB-10V	
DL Series	Current	Standard							DL2000ID
		Calibration Winding							DL2000ID-CD100 DL2000ID-CB100
	Voltage	Standard							DL2000UB-1V DL2000UB-10V
DQ Series	Current	Standard			DQ200-ID		DQ500ID DQ600ID		
		Programmable					DQ640ID-B		
DN Series	Current	Standard					DN1000ID		
DT Series	Current	Standard	DT50ID	DT100ID	DT200ID				
DW Series	Voltage	Standard					DW500UB-		

2.2 Description

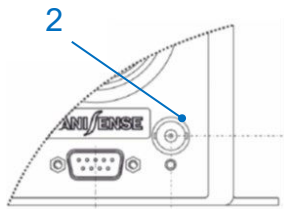
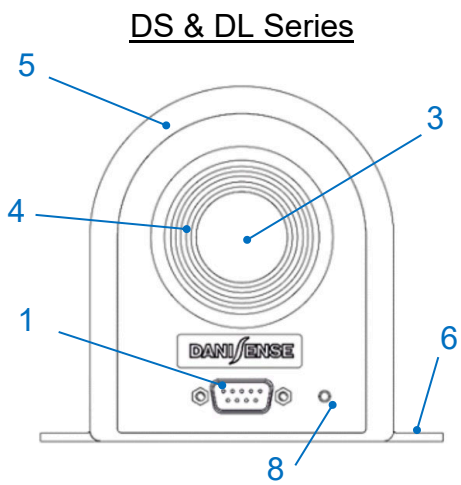
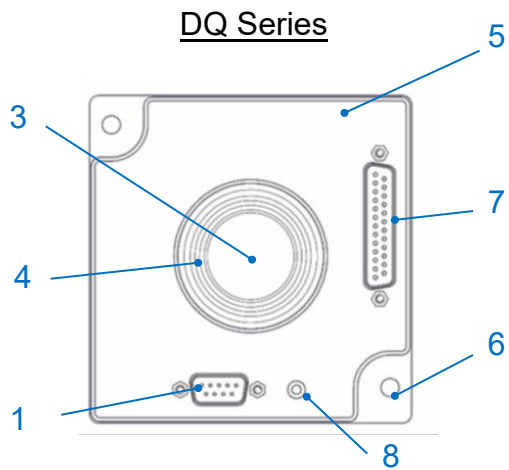
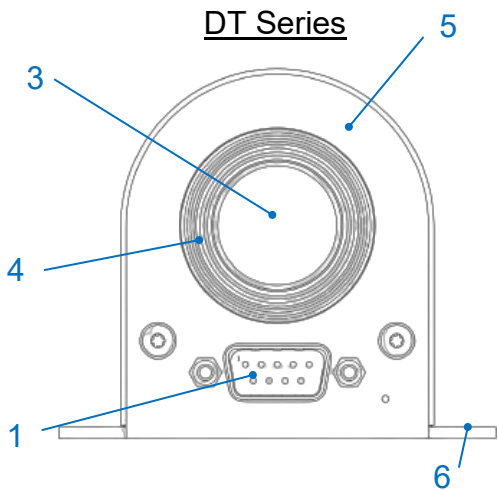

1. Main connector (power supplies, output signal, status etc.)
2. Voltage output or calibration winding terminals
3. Primary conductor feed-through hole
4. Insulating conductor guide
5. Complete metal housing
6. Fixation plate
7. Ratio programation connector (for DQ640ID-B model)
8. Green LED status indicator (lit in normal operation)

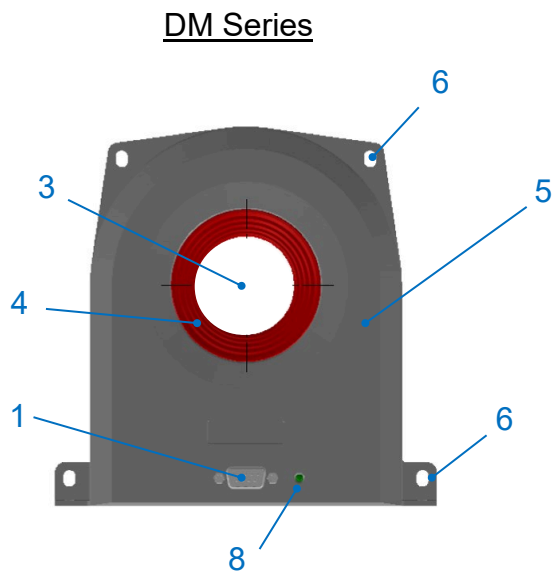
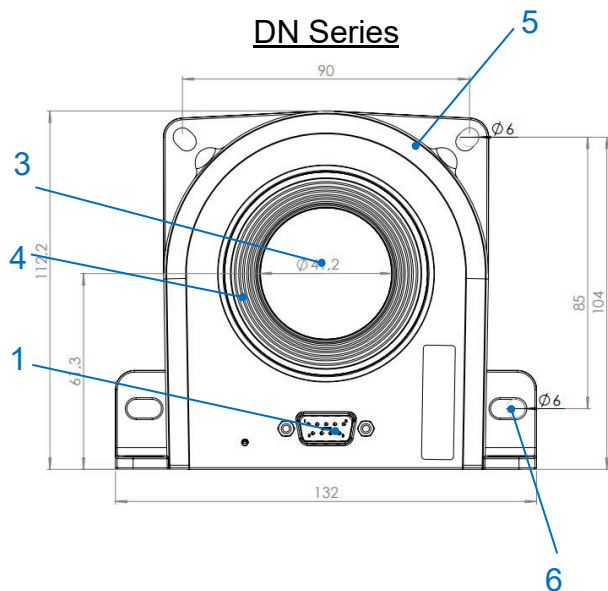

2.3 Installation & Operation

2.3.1 Mounting instructions

2.3.1.1 Positive current flow: Each transducer is marked with an embossed arrow at the back of the housing for the positive current direction, as shown below. Please respect the current flow indication to ensure that the output signal is in phase with the input signal.

DQ Series

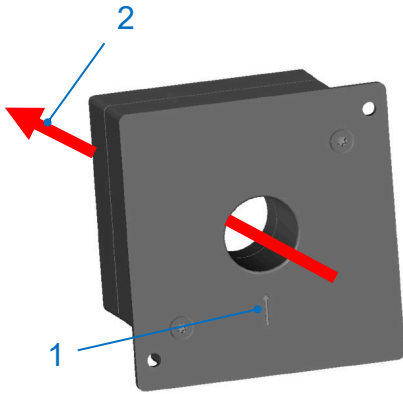

DS, DL & DT Series

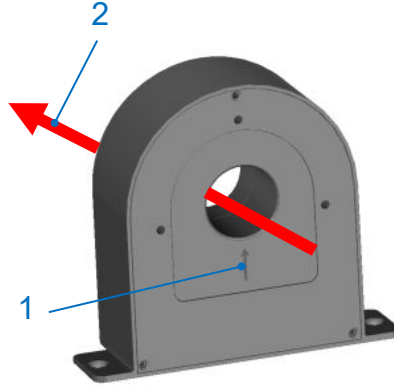

DM & DN Series

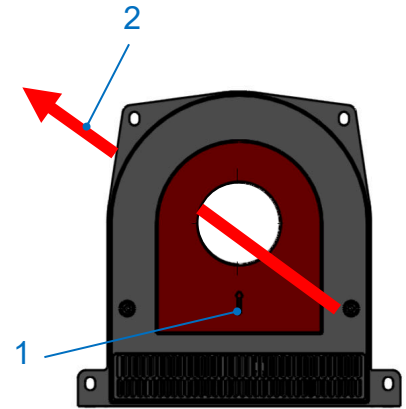

1. Arrow symbol
2. Positive current

2.3.1.2 Fastening torques: The devices is suitable for different fixation configurations, using the mounting plates designed for that purpose.

Please respect the fastening torques indicated below to avoid damaging the device.

DS Series

DQ Series

Base plate mounting

Backside panel mounting

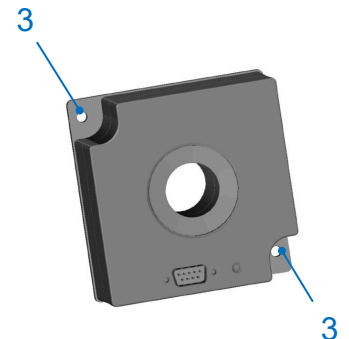
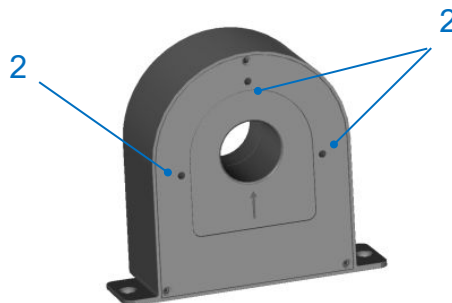
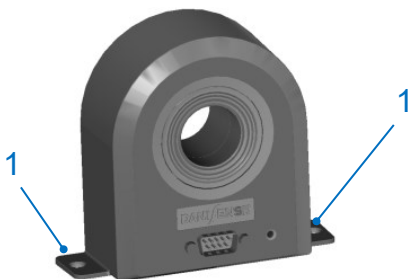

1. 2 holes Φ 6.5mm for 2 x M5 steel screws / 6N.m

2. 3 tapped holes Φ 4.0 x 6H for 3 x M4 steel screws / 4N.m

3. 2 holes Φ 5.5mm for 2 x M5 steel screws / 4.4N.m

DM & DN Series

Base plate and vertical mounting

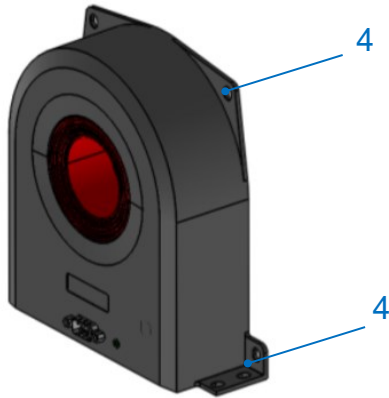

4. 4 holes Φ 6.0 x 11 mm for 4 x M5 steel screws / 6N.m

DL Series

Base plate mounting

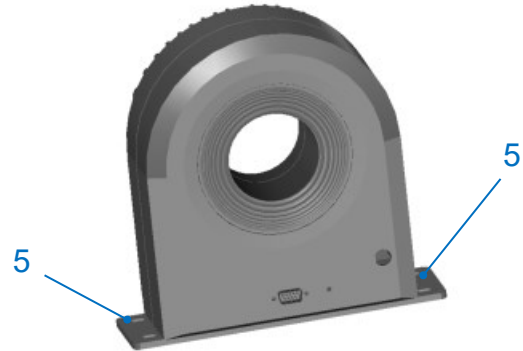

5. 4 holes Φ 5.5 x 11 mm for 4 x M5 steel screws / 6N.m

2.3.2 Electrical connection instructions

This chapter describes the electrical connection of the transducer according to their types of output (current or voltage).

2.3.2.1 Current output

Current output models are identified by the letter **I** in their model names (e.g. DS200**I**D).

2.3.2.1.1 Standard version

Electrical connection is ensured by a standard 9-pin DSUB connector (DSUB9). Jackscrew socket tapped hole UNC 4-40 inches ("D-SUB JACKSKT-SCREW, UNC 4-40, UNC 4-40" inches). The pin assignment is shown below.

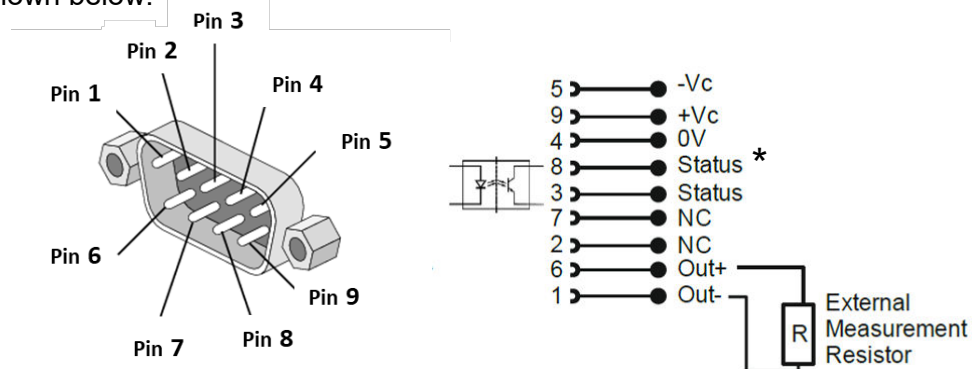

It's necessary to connect the output pins to an External Measurement Resistor to enable the current feedback loop (zero flux) for a correct operation of the device. Please refer to chapter 4.4 on External Measurement Resistor for more details.

* open collector for status signal: when the transducer is operating in normal condition, status pins are shorted. Status pins are open in case the « zero flux » state is not maintained (transducer is saturated or faulty).

Status pin properties:

- Forward direction pin 8 to pin 3
- Maximum forward current 10mA
- Maximum forward voltage 630V
- Maximum reverse voltage 5V

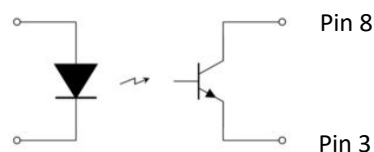

2.3.2.1.2 Version with calibration winding

For some applications, it's preferable to perform a prior functional / accuracy check of the device at full scale or a fraction of full scale before applying the power. For that purpose, a primary winding, most commonly of 100 turns or 1000 turns is added. The terminals of this winding are available at pin 2 and 7 of the DSUB9 connector (e.g. DS200ID-CD1000) as shown below

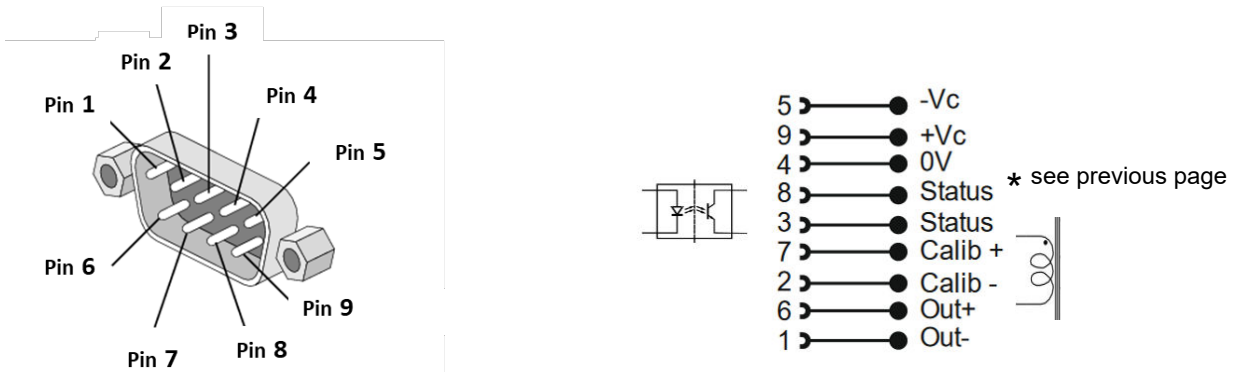

It's also possible to have the terminal of the calibration winding on a separate BNC connector (e.g. DS200ID-CB1000). For this version, the electrical connection is similar to the voltage output model in the following section.

Thin wire are used for the test winding due to space restriction. Please observe the current limit for the test winding, specified in the relevant datasheet to avoid damage to the wire.

2.3.2.2 Voltage output

Voltage output models (10V or 1V at rated current) are identified by the letter **U** in their model names (e.g. DS200**U**B-10V). The transducer's output signal is accessible via the BNC connector to enhance immunity to induced noises as shown below .

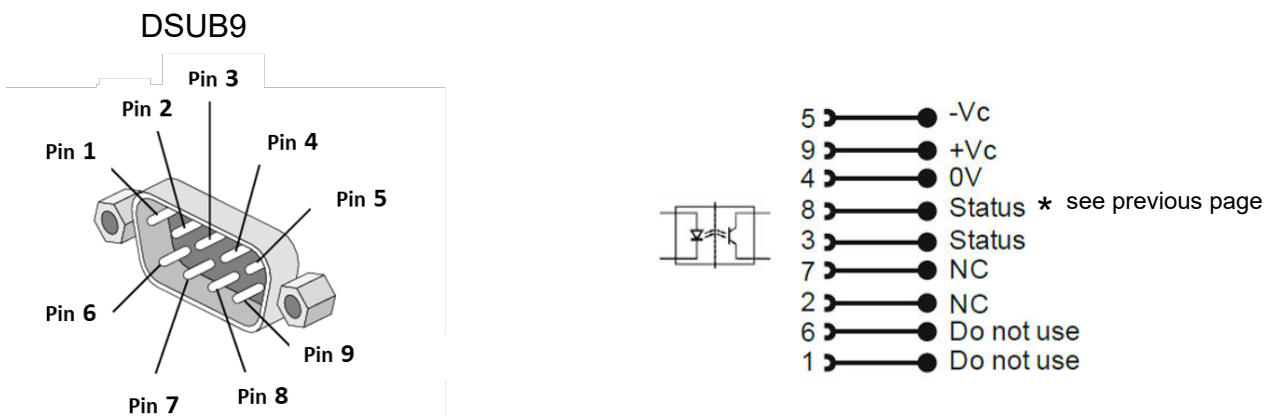
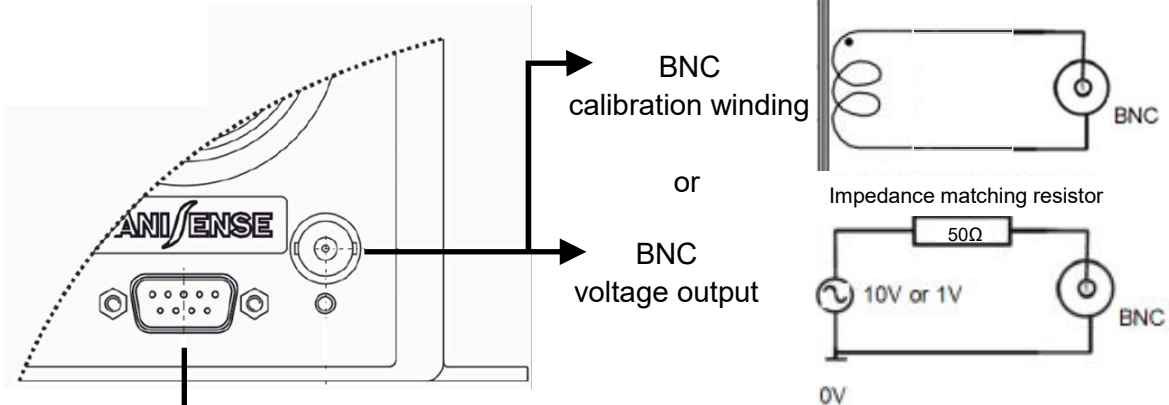

2.3.3 Power supplies interface units

2.3.3.1 Main features

The current transducers are designed for operation with a $\pm 15V$ DC power supplies with the following requirements:

- Tolerance max: $\pm 15VDC \pm 5\%$
- Max. ripples: 15 mVrms
- Mini. Current requirement *: I consumption (Ips or Ins) + secondary current Is @ max. primary current (see below example)

* e.g. DS600ID measuring up to $\pm 900A$.

- I consumption (see datasheet) Positive current consumption Ips: 104mA
Negative current consumption Ins: 96mA
- Secondary current Is (ratio: 1:1500) $I_s = \pm 900A \times (1:500) = \pm 600mA$

The minimum current that the power supply needs to provide is:

For +15VDC, I output = Ips + Is = 104 + 600 = 704mA

For -15VDC, I output = Ins + Is = 96 + 600 = 696mA

2.3.3.2 Multi-channels power supplies interface DSSIU series

Danisen recommends the 1U rack-mount multi-channels power supplies interface DSSIU series for best performances, many useful features and options. The following table shows the different options:

Model	DSSIU-4-1U	DSSIU-6-1U	DSSIU-6-1U-V
Number of channels	4	6	6
Standard current output	4mm Banana jacks (red/black)	4mm Banana jacks (red/black)	Mini XLR connector
Voltage output modules	none	none	Mini XLR connector
Terminals for calibration winding	none	4mm Banana jacks (yellow)	4mm Banana jacks (yellow)
Max. capacity	Up to 4 DL2000 /3000A at the same time	Up to 4 DL2000 /3000A at the same time	Up to 4 DL2000 /3000A at the same time



Features DSSIU-4, DSSIU-6

- Output voltage: $\pm 15V \pm 5\%$ (per channel)
- Input voltage: AC 100V to 240V, 47Hz to 63Hz
- Dimensions: 19" rack, 1U in height

DSSIU-4-1U



DSSIU-6-1U

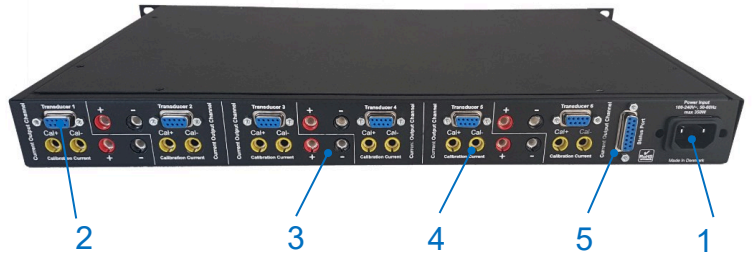

DSSIU-6-1U-V

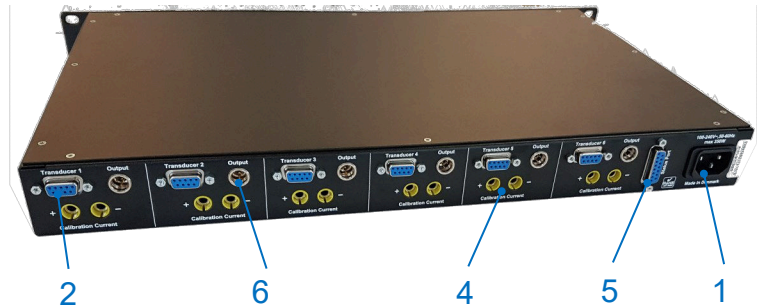

1. Mains voltage
2. DSUB9 connector for transducer connection
3. Banana jacks for transducer's current output
4. Banana jacks for calibration winding terminals
5. Status connector
6. Mini XLR socket for transducer's voltage or current outputs

2.3.3.3 Connection of calibration winding with DSSIU-6-1U (or DSSIU-6-1U-V)

When a device with calibration winding type - CD[n turns] is connected to the DSSIU-6-1U using the optional DSUB cable, the terminals of the calibration winding are accessible via the yellow banana sockets at the back panel of the DSSIU-6-1U (or DSSIU-6-1U-V). It's very convenient to carry out a simultaneous calibration of 6 devices connected in serial (illustration below).

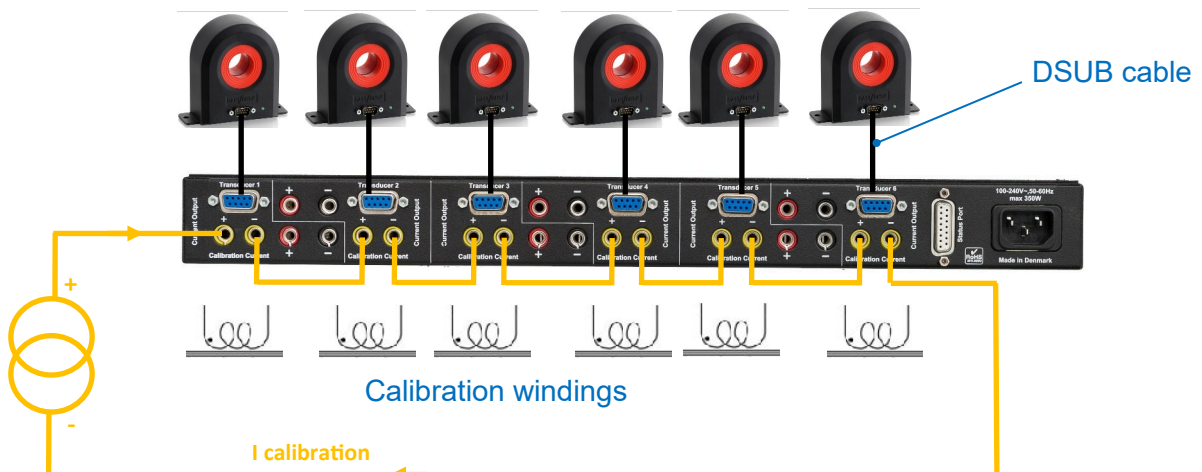

2.3.3.4 Voltage Output Modules (VOM)

A voltage output module (VOM) is a PCBA containing a low drift, precision measurement resistor (R_m) and a signal conditioning circuit which allow conversion of the device's rated nominal current output to a 1V or 10V voltage signal. Up to 6 VOMs can be factory mounted into the 6-channel power supplies interface unit (DSSIU-6-1U-V).

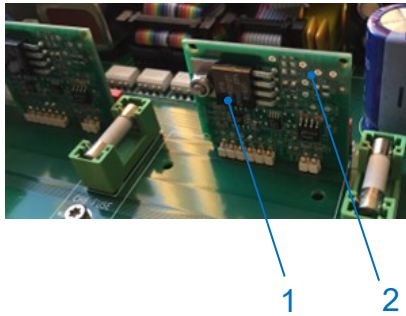

1. measurement resistor R_m
2. conditioning circuits

Reference	VOM0400-1	VOM0400-10	VOM1333-1	VOM1333-10
Conversion ratio	1V@400mA	10V@400mA	1V@1.333A	10V@1.333A

The voltage output signal is accessible at the back panel of the DSSIU-6-1U-V, via a 3-pin Amphenol mini XLR connector, (refer to figures page 9).

Please specify the required VOM reference, the channel number when making your purchase (e.g. CH1: VOM0400-10, CH3: VOM0400-10, CH5: VOM1333-10 as shown below in the picture below)



Each voltage output channel is identified by an individual label

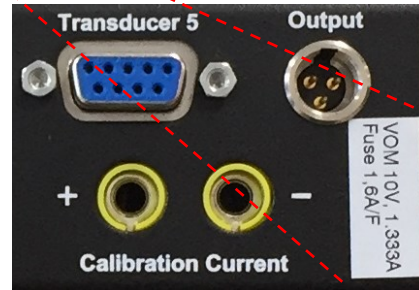

2.3.3.5 DSSIU-6-1U-V current / voltage output cables

These cables are available as optional accessories.

Reference	
XLRm / Banana current cable (2m)	This cable is equipped with a min XLR connector at one end and 2 banana jacks at the other end (Iout+/Iout-)
XLRm / Banana voltage cable (2m)	This cable is equipped with a min XLR connector at one end and 3 banana jacks at the other end (Vout/OV/shield)



XLRm / Banana
Current Cable (2m)



XLRm /Banana
Voltage Cable (2m) with shielding for better immunity

2.3.3.6 Noises immunity of voltage output versions

Compared to current output devices, voltage output models are generally less immuned to induced noises from external sources. In the following schematics, two configurations are shown.

Config. 1: Current transducers with voltage output (e.g. DS600UB-1V)

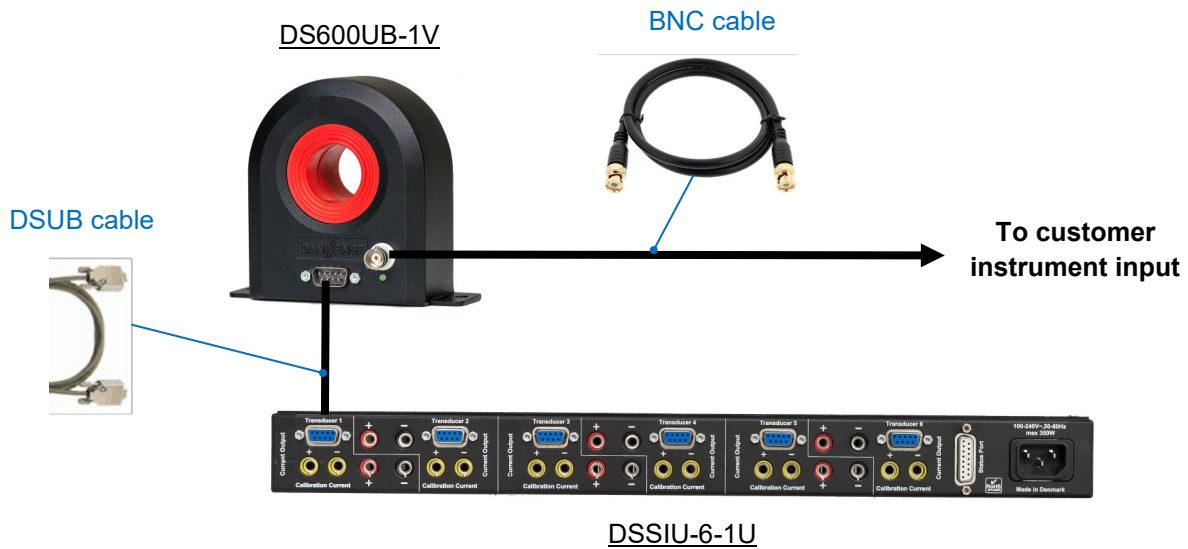

CAUTION Voltage output transmitted through BNC cable is to a certain extent influenced by external noises, especially when long cable is used.

Config. 2: Current transducers with current output (e.g. DS600ID) + DSSIU-6-1U-V (with factory mounted VOM0400-1)

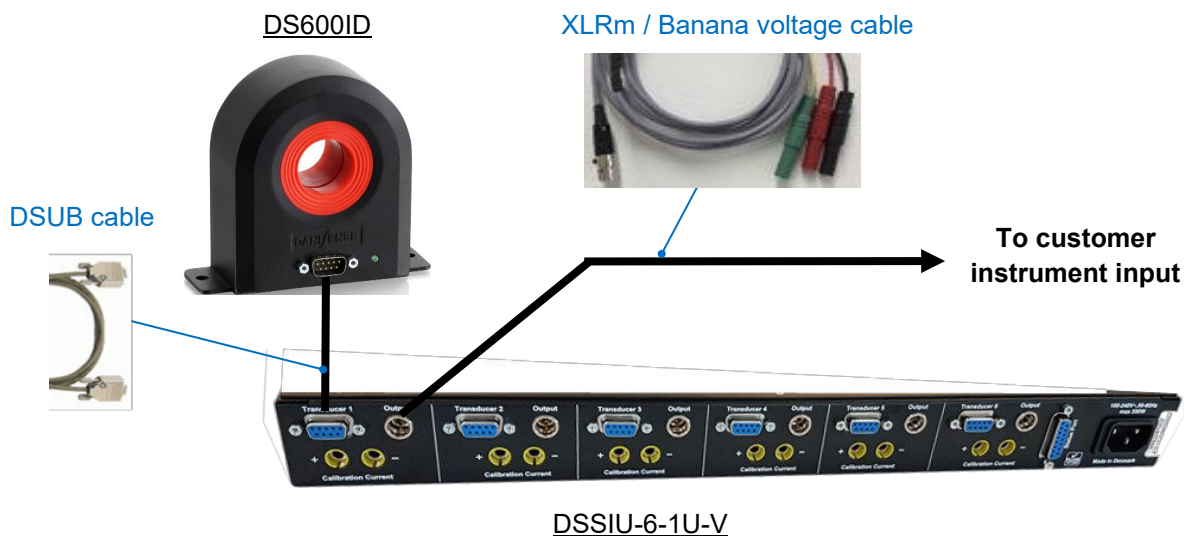

The XLRm / Banana Voltage shielded cable in configuration 2 is relatively better immuned to induced noises than the BNC cable in configuration 1.

3. SEPARATE HEAD TRANSDUCER SYSTEMS (DR series)

3.1 Introduction and overview

The DR series, ultra-stable and high precision current transducers are based on closed loop flux gate principle allowing to achieve ppm level accuracy, excellent linearity and stability versus time. The sensing head is connected to the control electronics by a dedicated shielded cable with several lengths in option. The following table shows the rated current range overview and model names.

Family Name	Output type	Primary current Arms			
		1000A	2000A	5000A	10000A
DR Series	Current			DR5000IM	DR10000IM
	Voltage	DR1000UL-10V	DR2000UL-10V	DR5000UX-10V/7500A	DR10000UX-10V

3.2 Description

DR Series < 5000A

DR Series ≥ 5000A

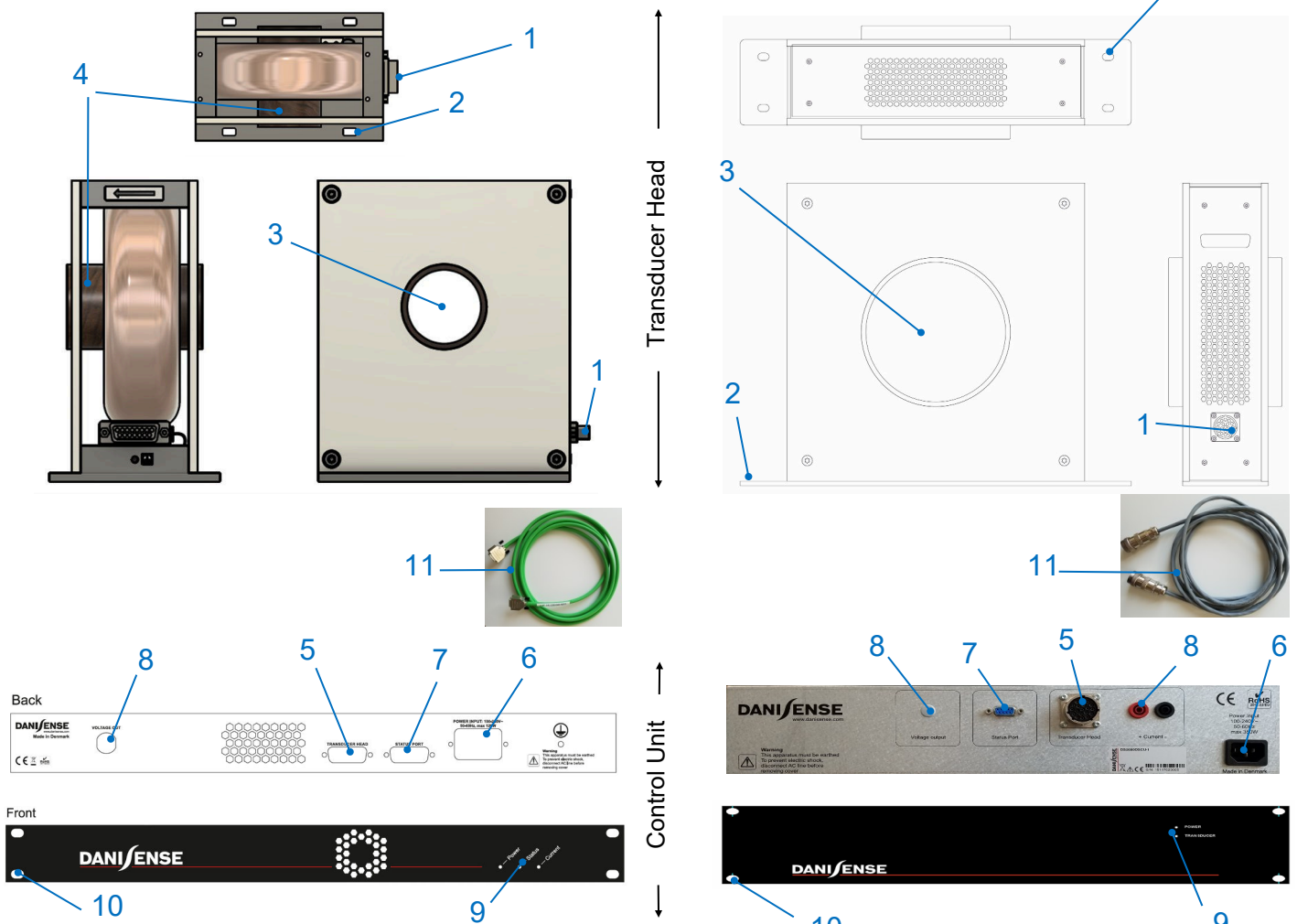

1. Output connector of transducer head
2. Transducer head fixation plate
3. Primary conductor feed-through hole
4. Insulating conductor guide
5. Input connector from transducer head
6. Main power supply plug

7. Status connector
8. Output connector (current or voltage)
9. Green LED status (lit in normal operation)
10. Control unit fixation plate
11. Head - Control unit connection cable

3.3 Installation & Operation

3.3.1 Mounting instructions

3.3.1.1 Positive current flow: each transducer head is marked with an arrow at the side of the housing for the positive current direction, as shown below. Please respect the current flow indication to ensure that the output signal is in phase with the input signal.

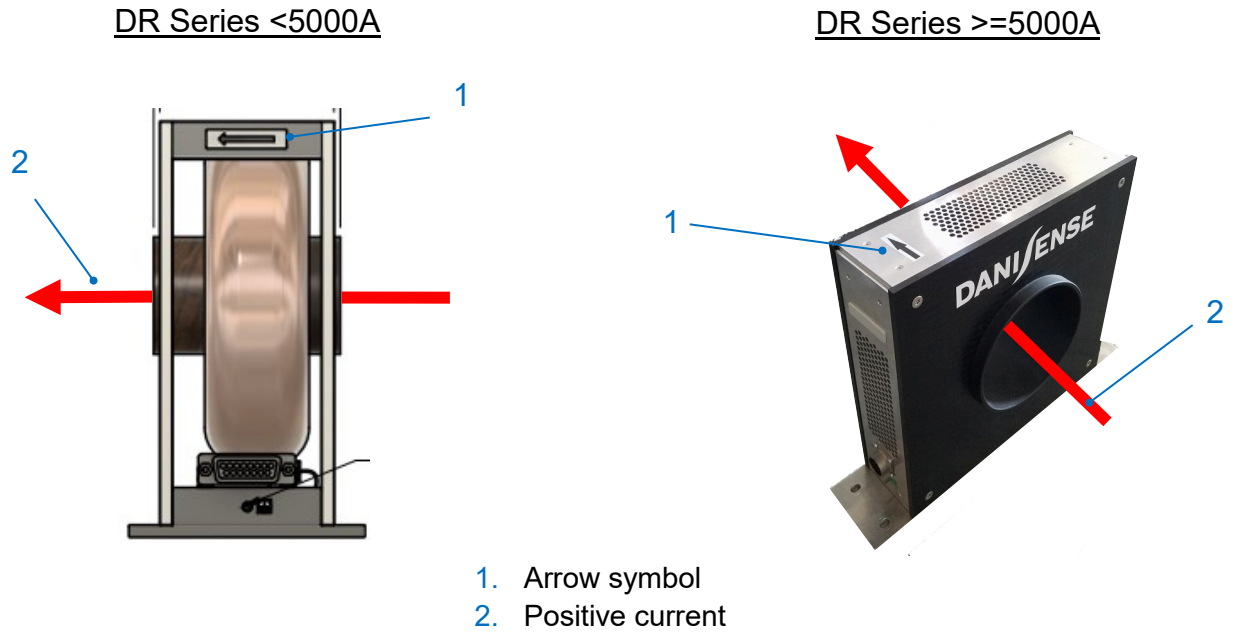

3.3.1.2 Mechanical fixation

The transducers heads can be mechanically fixed by using the mounting plates designed for that purpose and shown below:

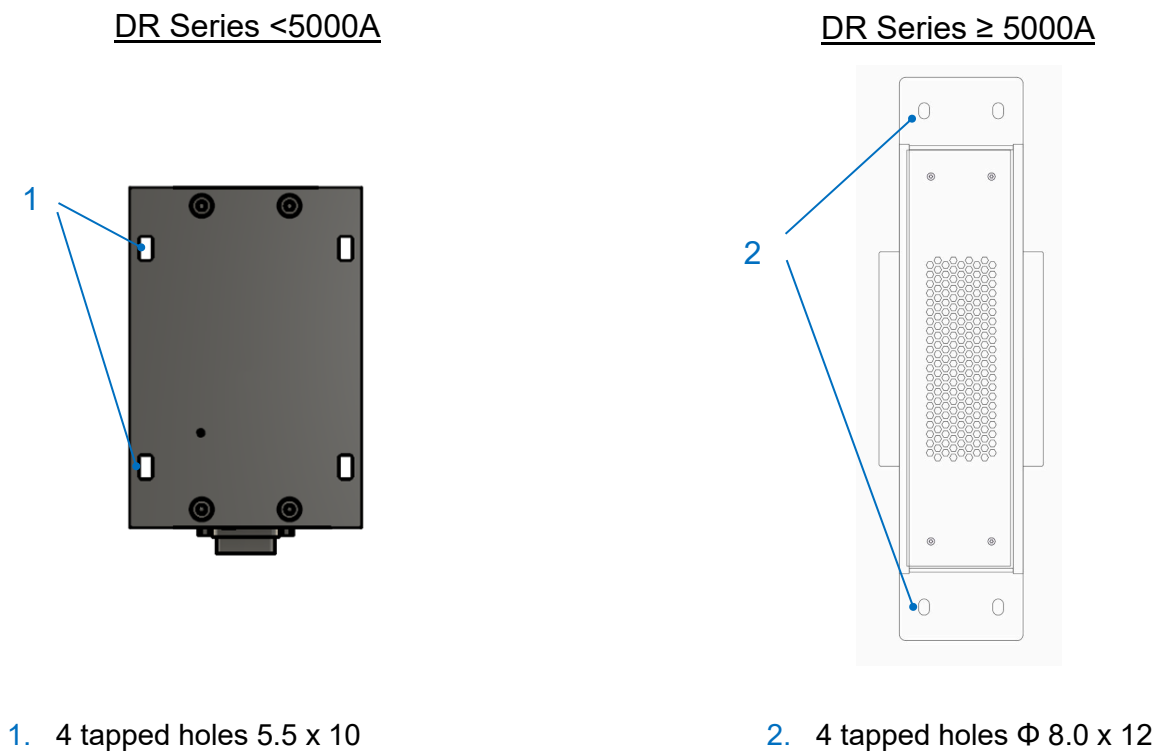

The control unit is rack mountable which can be mechanically fixed by using the mounting holes on the front side as shown below:

DR Series <5000A

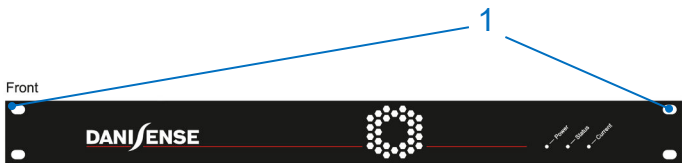

1. 4 tapped holes Φ 8.0 x 12
rack mountable, 1U high control unit

DR Series \geq 5000A

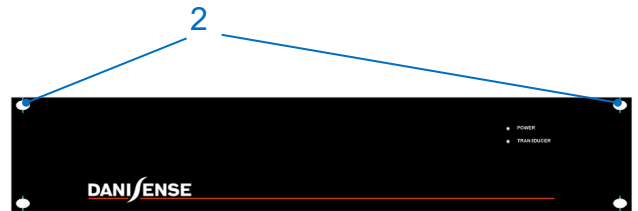

2. 4 tapped holes Φ 8.0 x 12
rack mountable, 2U high control unit

3.3.2 Electrical connection

This chapter describes the electrical connection of the transducer according to their types of output (current or voltage) and the connection between the sensing head and the electronic rack.

3.3.2.1 Current output

Current output models are identified by the letter **I** in their model names (e.g. DM5000**I**M). Currently this version exist only for $I \geq 5000A$.

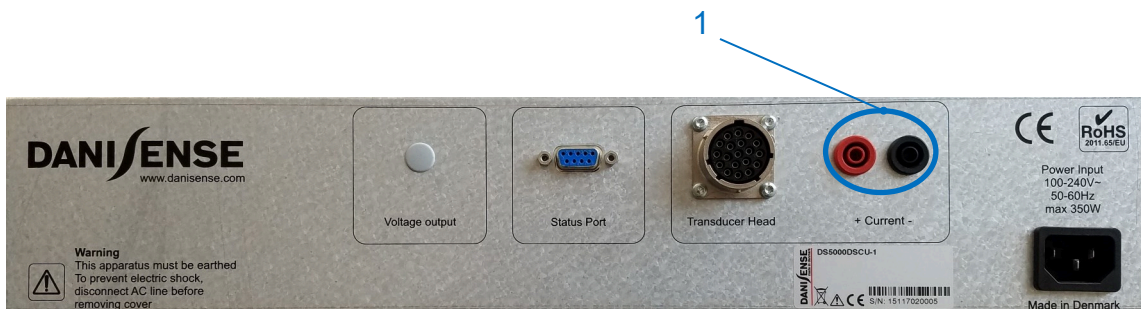

1. For DRxxx**I**M : 4 mm Banana sockets for output current

It's necessary to connect the output pins to an External Measurement Resistor to enable the current feedback loop (zero flux) for a correct operation of the device. Please refer to the individual datasheet on Maximum Measurement Resistor graph for more details.



WARNING

PLEASE CONNECT THE SENSING HEAD TO THE CONTROL UNIT USING THE PROVIDED CABLE ALL THE TIME POSSIBLE.

The sensing head consists of many windings which behave like an ACCT. It must be connected to the control unit to avoid high induced voltage in case AC currents are mistakenly flown through the aperture of the head. The high induced voltage could be dangerous to an operator or destroy the head.

3.3.2.2 Voltage output

Voltage output models (10V at rated current) are identified by the letter **U** in their model names (e.g. DR5000**U**L-10V).

DR Series < 5000A

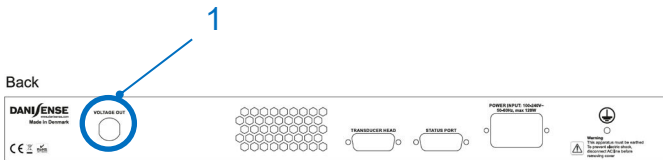

1. For DRxxxUL : 4 pins LEMO connector
ERA.2S.304.CLL

DR Series ≥ 5000A



2. For DRxxxUX : 3 pins XLR mini connector

XLRm /Banana Voltage Cable (2m) with shielding for better immunity is provided in the standard delivery package.



3.3.2.3 Connection transducer head to control unit

A dedicated shielded cable is provided for connection of the sensing head to the control unit. It's possible to specify a different length (between 5m and 30m) at the time of order. Please consult Danisense or our distribution partners for details.

DR Series < 5000A



DR Series ≥ 5000A



For the model >5000A find below some specific instructions for the connector.



WARNING

TRANSDUCER HEAD AND CONTROLLER RACK MUST BE CONNECTED BEFORE POWER ON OR TURNING ON PRIMARY CURRENT.

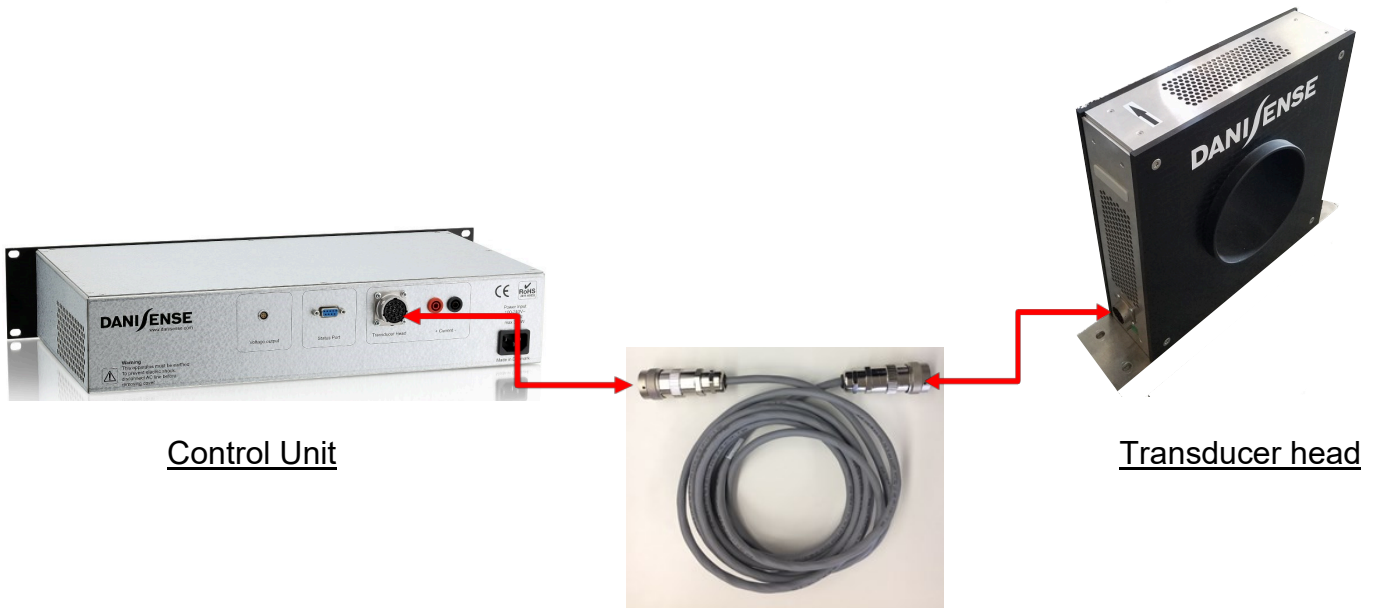

Control Unit

Transducer head

Connection (plug in) instructions:

1. Match keys and keyways on male & female connectors to prevent pins damage by mis mating.

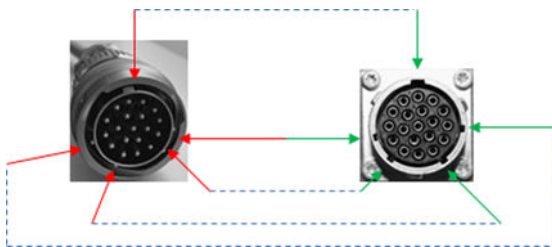

2. Preliminary insertion (around 1mm) while keeping male & female connectors aligned

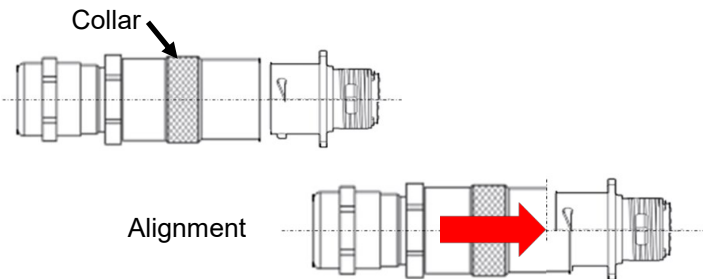

3. Turn collar clockwise for full insertion until a "click" sound is heard

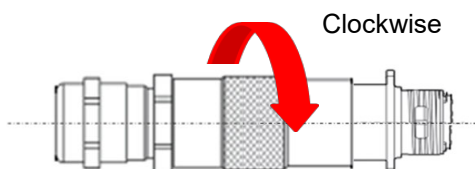

Disconnection (unplug) instructions:

1. Push collar forward (for unlocking) and at the same time turn it anti-clockwise for disconnection

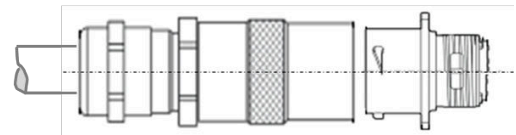
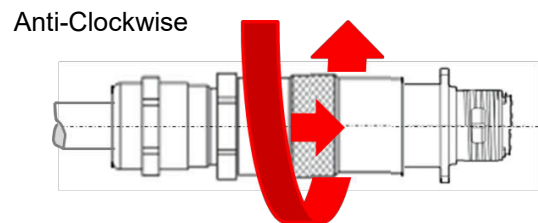

4. ELECTRICAL CONSIDERATIONS

4.1 Common mode noises

Common mode noises occur when high dV/dt in switching circuits such as inverters, switch mode power supplies etc. generates parasitic currents i_p circulating through stray capacitance C_s that exists between the parts of an electronic component or circuit simply because of their proximity to each other. The value of i_p is determined by the following formula:

$$i_p = C_s \times dV/dt$$

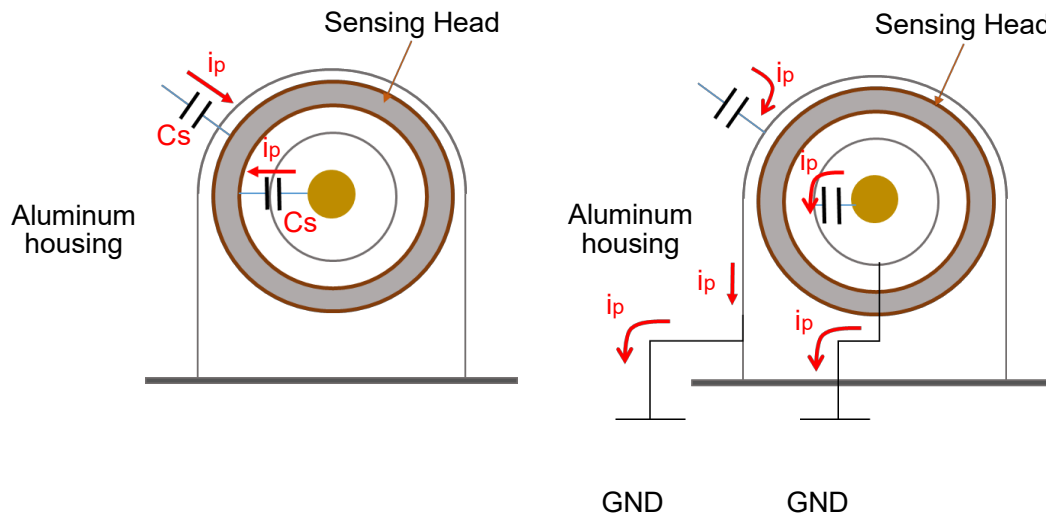

Grounding of aluminum housing helps to divert capacitive currents off the sensing head and as a consequence greatly improve immunity to common mode noises.

As the aluminum case is painted with a black insulated coating, it's recommended to slightly scratch the surface of the housing, at the area around the fixation hole(s) to expose the metal material for grounding purpose.

It's also possible to do the grounding using the external shell of the DSUB connector which is electrically connected to the aluminum housing

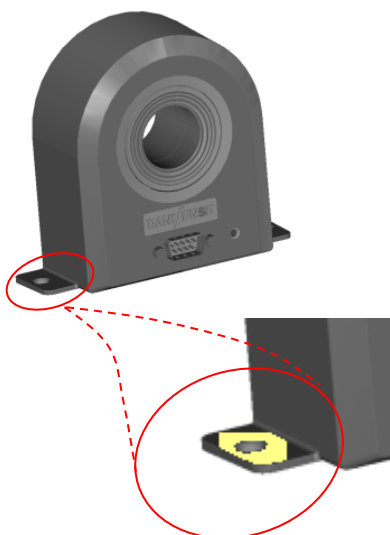

The external shell of the DSUB connector is electrically connected to the aluminum housing

4.2 Ground Loop Currents Consideration

Ground loop current is a phenomenon frequently encountered in electrical connection of various measurement devices. It's caused by voltage differences that normally exist between "Grounds" of various devices.

The voltage difference could be significant in case of long connection, resulting in the circulation of a ground loop current with potential to damage the electronic components of a DCCT.

In the following, the ground loop current mechanism and its effect on a DCCT is explained.

4.2.1 Standard setup

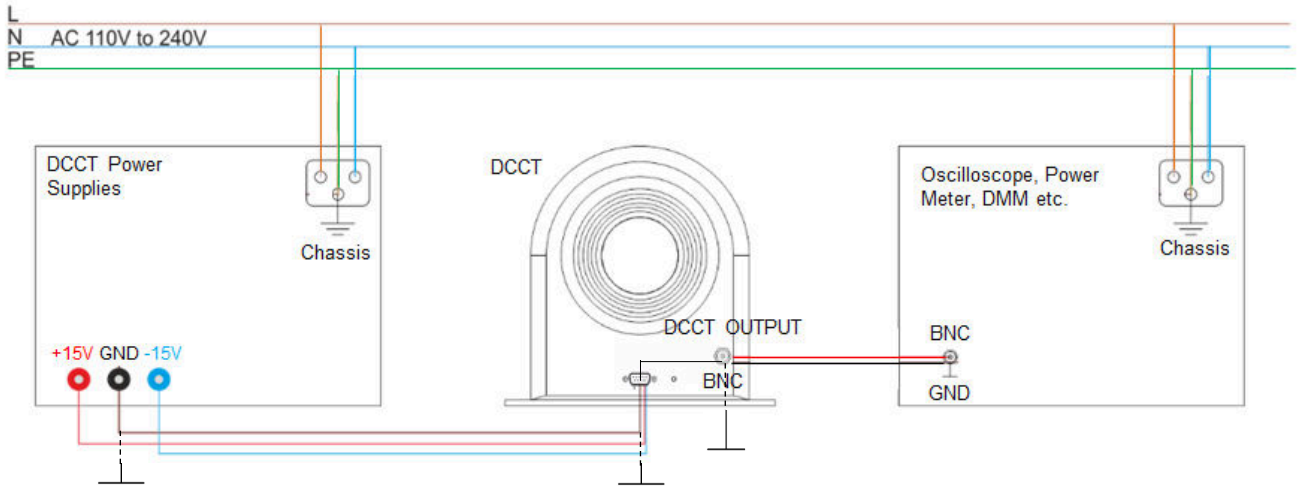

The illustration above shows the standard setup which includes a DCCT, its +/-15V power supply and a measurement instrument such as a power meter. The +/-15V power supply and the power meter are connected to the AC power network, with their respective chassis "earthed" (grounded) for safety reason (green lines).

However in the above setup, if the chassis --- of the PS or measurement devices are connected to the electronic ground --- , this will create a "ground loop" (see bold, purple dotted lines in the illustration below)

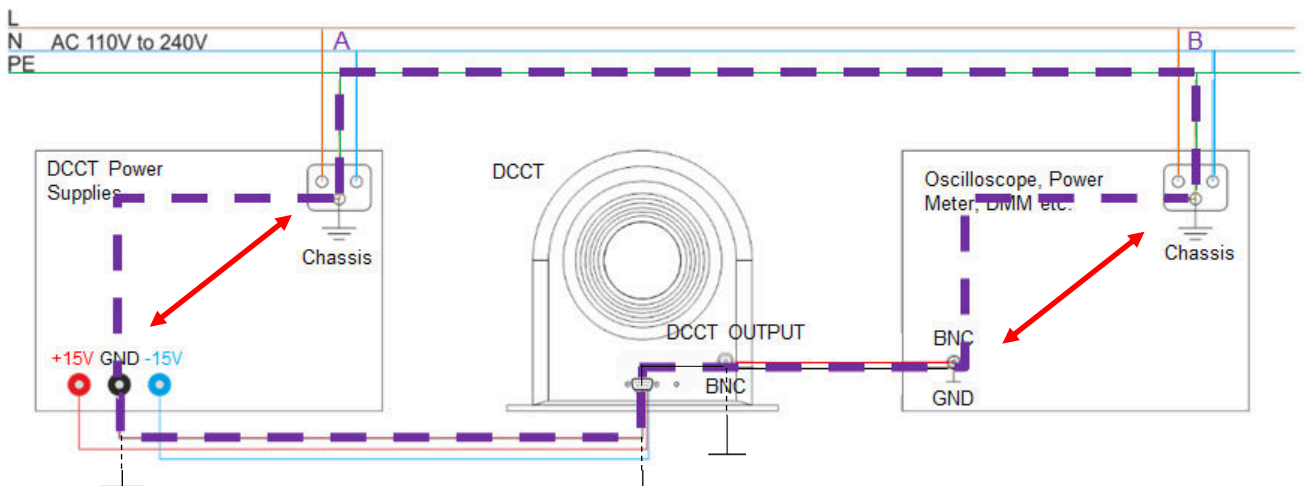

The formation of a "ground loop" through the connection of the electronic GND to the devices' chassis, will enable the circulation of a ground loop current, generated by the difference of electric potential between the two points "A" and "B".

The parasitic ground loop current in general will manifest as noises observed on the output signal of the DCCT. However, we've seen practical cases from our users where the potential difference is substantially high enough to create parasitic current of tens of mA order. This can permanently damage electronic components of the DCCT (please refer to the illustration in the next page)

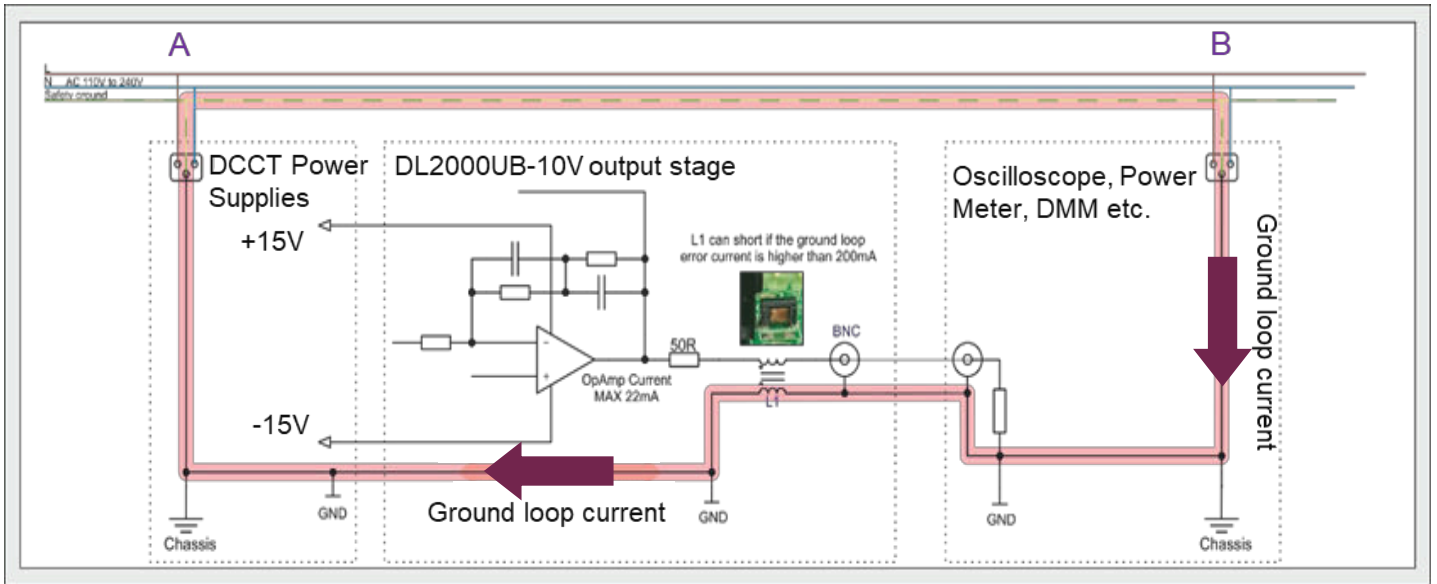

The illustration above describes the output stage of the DL2000UB-10V model and shows the example of a bad connection with a ground loop. Let's assume that the electric potential of point B (where the chassis of the measurement device is connected) is higher than that of point A (where the chassis of the DCCT power supply is connected). This generates a parasitic ground loop current represented by the purple arrows that run directly through the coils of the DCCT output filter L1 (absolute rating: 200mA). This ground loop current could damage the output filter L1 or the output operational amplifier (absolute rating 22mA).

RECOMMENDATIONS:

To avoid ground loop currents, please ensure that the chassis (Earth) of the DCCT +/-15V power supply and /or those of various measurement devices are NOT connected to the GROUND of the electronics.

DANISENSE's DSSIU power supply offers protection against ground loop currents:

DANISENSE multi-channel DCCT power supply interface units, model DSSIU-4-1U (max. 4 DCCT) and DSSIU-6-1U (max. 6 DCCT) are designed with a 1M Ohm resistor and a 1uF/100V capacitor between its chassis and 0V (electronic GND) to protect the DCCT from damage caused by ground loop current (refer to the illustration below).

We strongly recommend the use of DSSIU power supplies and DSUB connection cables for a full protection against ground loop currents and wrong pins assignment which destroy the DCCT.

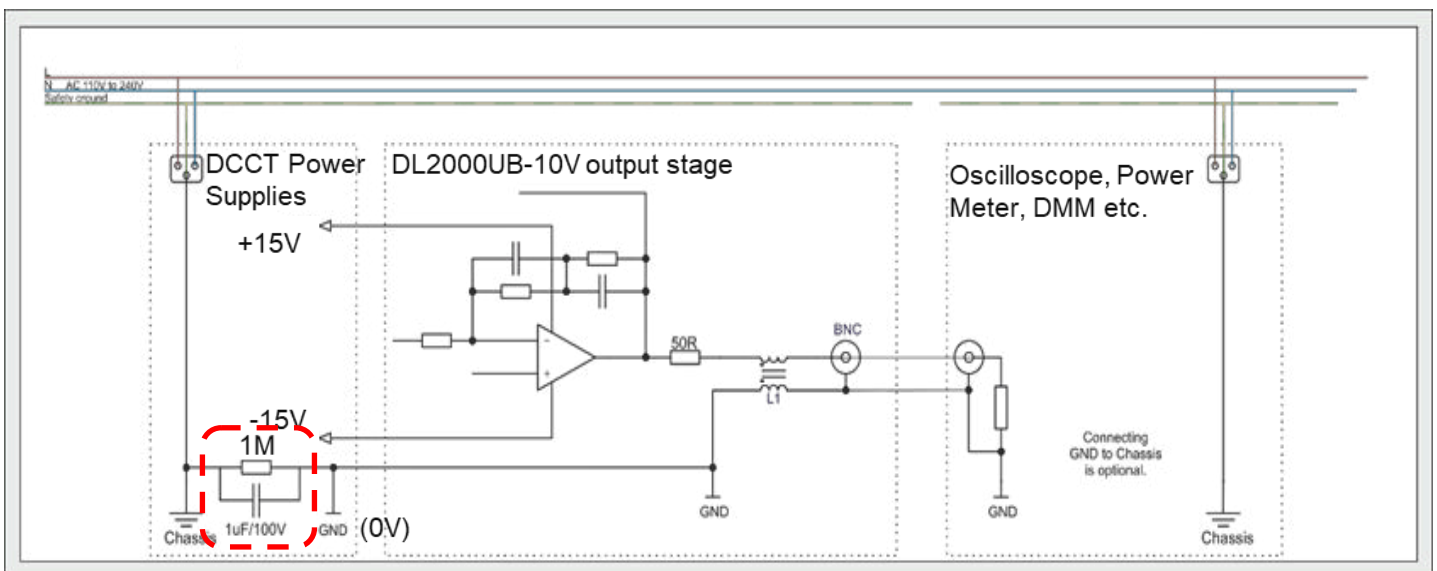

4.2.2 Other problematic example of connection set up

The following set up, although not very common, presents a high risk of damaging the DCCT by ground loop current.

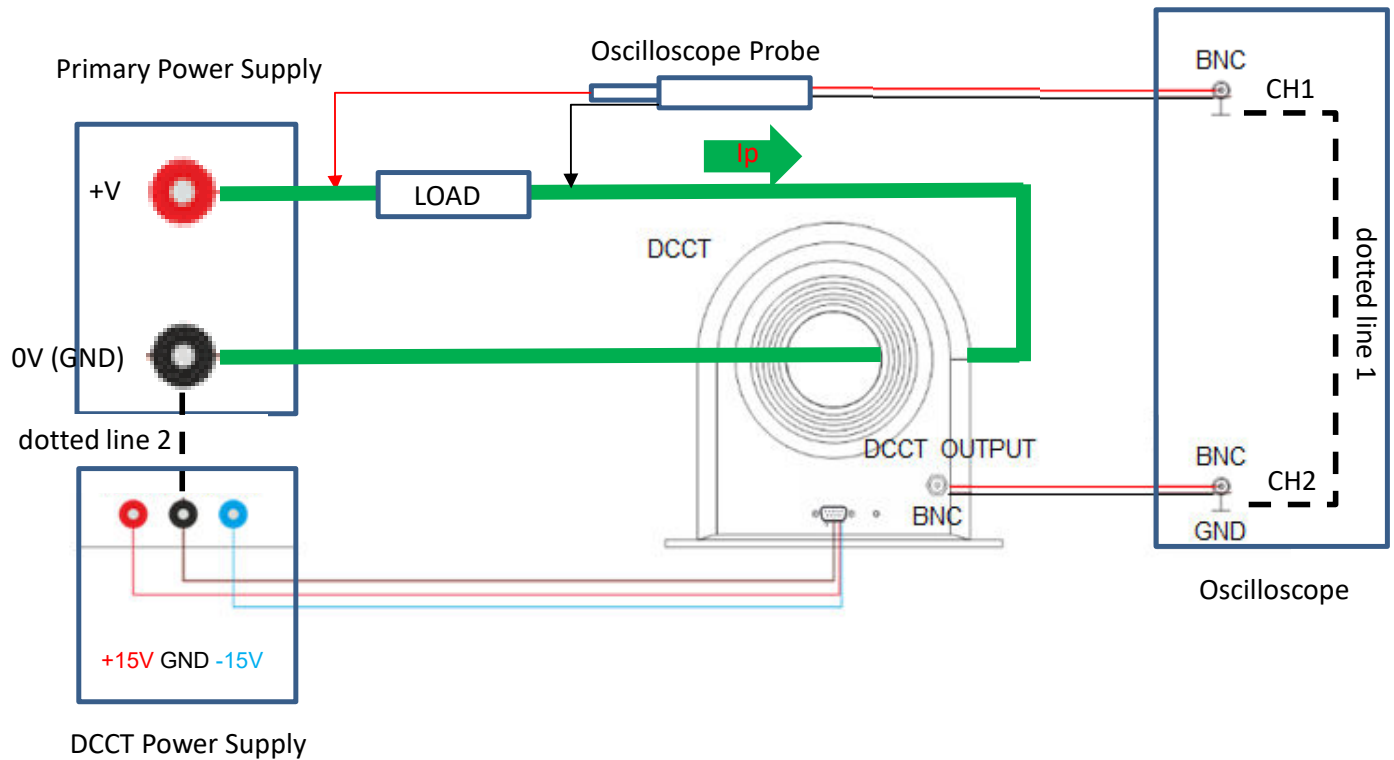

The primary current I_p is observed on CH1 of the oscilloscope (or a power meter) via a probe which measures the voltage drop across a load. On the other hand, the output signal of the DCCT is connected to CH2 of the same instrument.

Most oscilloscopes use a common ground for their various channels (dotted line 1). In the above set up, let's assume that the primary power supply and the auxiliary DCCT power supply have their respective 0V (GND) connected (dotted line 2). This will create a ground loop (see bold, purple dotted lines in the illustration below).

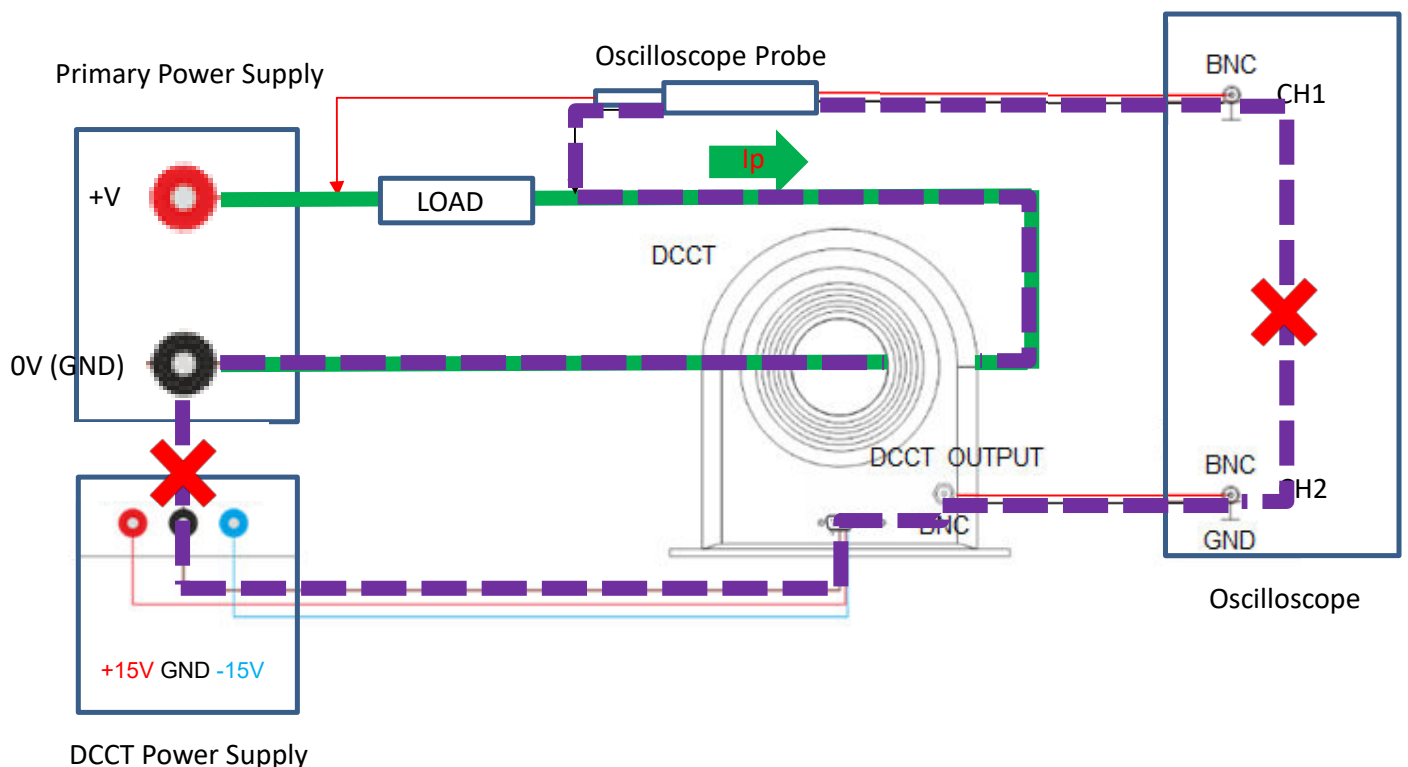

To avoid damage to the DCCT, in the above set up, it's recommended to use an oscilloscope (or power meter) with FLOATING channels or to disable the ground loop by disconnecting the GND of the primary and the auxiliary DCCT power supplies (see the red X marks).

4.3 Saturation behavior

The device is operating based on the flux compensation principle in which the magnetic flux generated by the primary current in the fluxgate element is cancelled to zero by the opposite magnetic flux from the secondary winding of the current transducer.

Saturation occurs when the current transducer is in a situation where it cannot output sufficient current to nullify the magnetic flux from the primary current.

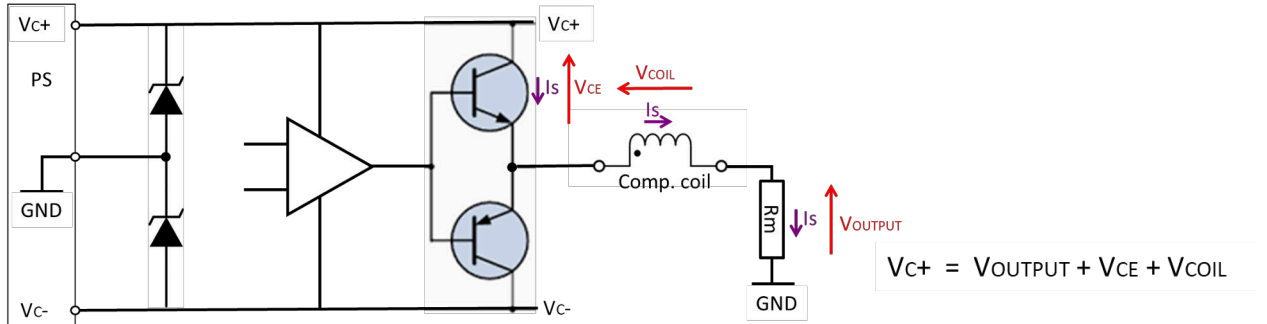

The above equation sets an upper limit value for V_{OUTPUT} (useful voltage). Consequently the output current I_s cannot go higher even if I_p further increases. This is called saturation. It happens when;

- a primary current overload,
- a too high measuring resistance R_M value,
- a primary current flows in the hole of the un-powered device etc.

When saturation occurs, the DS series is designed to hold the output signal high for a period up to 1 second as shown in the green color waveform below. During that period, if the overload disappears, the DS operates normally.

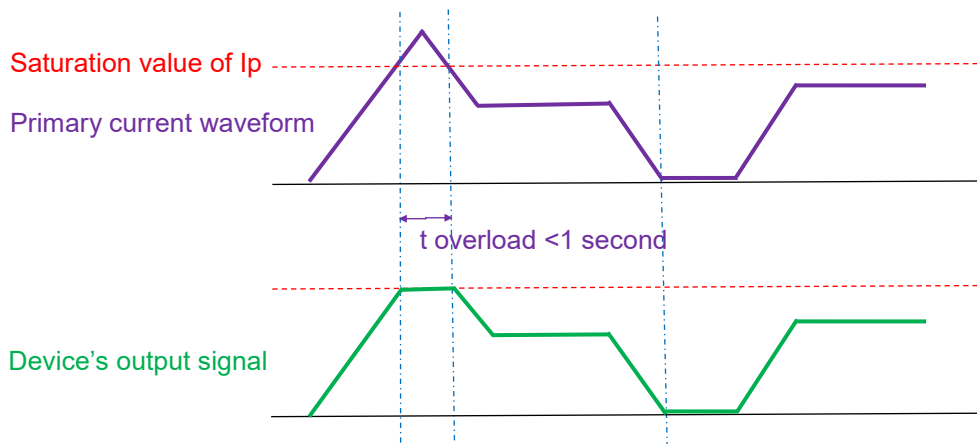

However, if the overload lasts longer than 1 second, the output signal of the DS will drop to zero and the primary current must return to near zero for the DS to operate normally again.

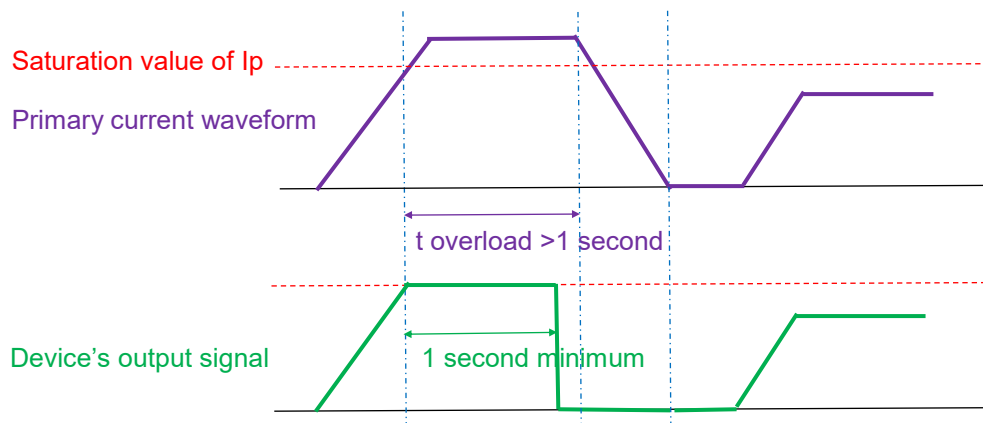

4.4 Influence of the return conductor

The magnetic field from the return branch of the primary current (cable / busbar) or of any adjacent conductors (e.g. the remaining phases of a 3 phase configuration) exerts a certain influence on the sensing core of a fluxgate current transducer (grey area of the illustration below). This causes local unbalance of the sensing part and creates measurement error.

To minimize the error cause by the return conductor (less than 10 ppm), we recommend a “return conductor FREE zone” (refer to the zebra zone of the illustration).

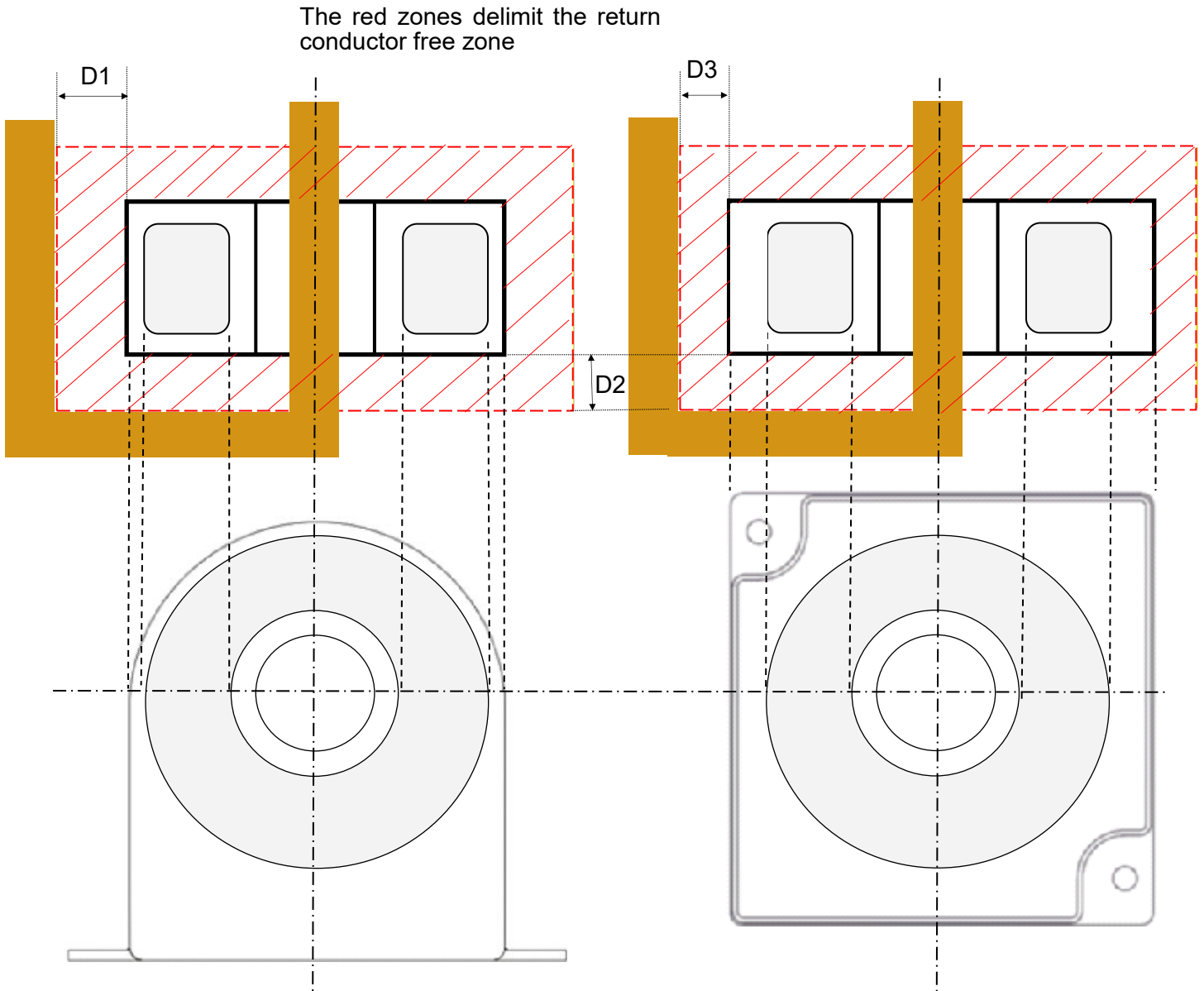

Model	DS200	DS400	DS600	DQ200	DQ400	DQ600	DN1000	DM1200
D1 (mm)	20	20	15	20	20	15	20	0
D2 (mm)	20	20	15	20	20	15	20	0
D3 (mm)	20	20	15	20	20	15	20	0

4.5 Derating of external measuring resistor R_M

The external measuring resistor R_M is a very important component to ensure the zero flux compensation and consequently a correct output current, refer to previous chapter 4.2.

To avoid saturation of the current transducer, value of R_M must be determined according to the derating curves shown in the individual datasheet. Below is an example of the derating curve for the DS400ID.

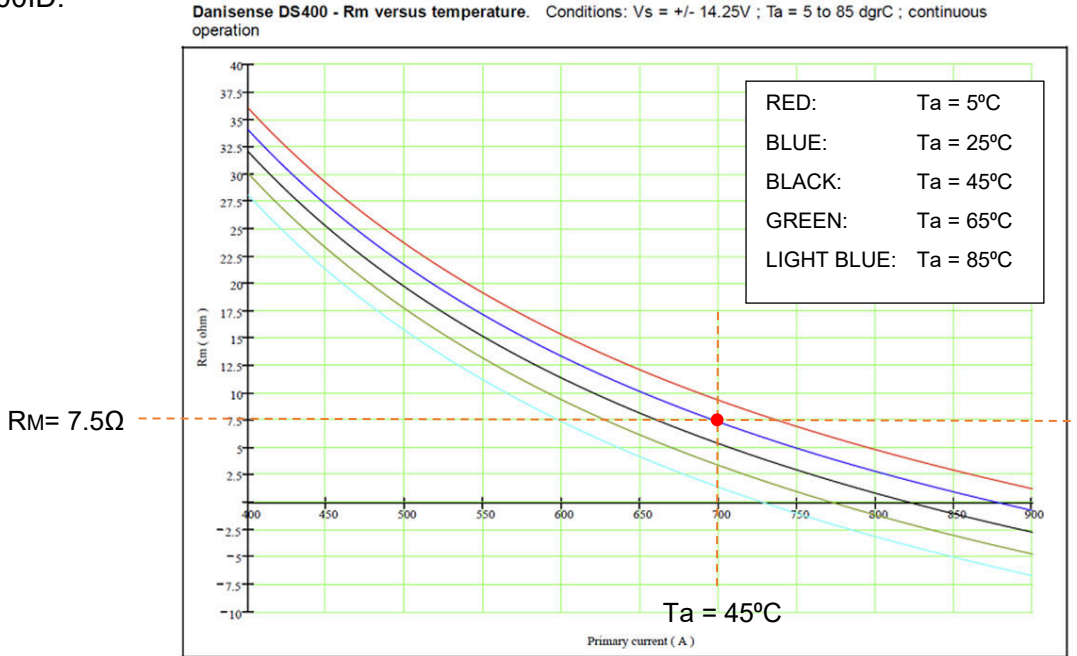

e.g. at ambient temperature $T_a = 25^\circ C$, the black curve shows that to measure up to 700A, R_M must be less than 7.5Ω

4.6 Frequency derating

Danisense fluxgate current transducers offer extreme precision in DC and low frequency. However, they also have excellent frequency bandwidth relative to similar products in the market thanks to fast switching speed of the fluxgate excitation circuit. High frequency AC current produces heat in the magnetic core. The frequency derating curves in the individual datasheets allow calculation of the max rms value of the primary current at a given ambient temperature, without damaging the transducer. Below is an example of the frequency derating curves of the DS600ID.

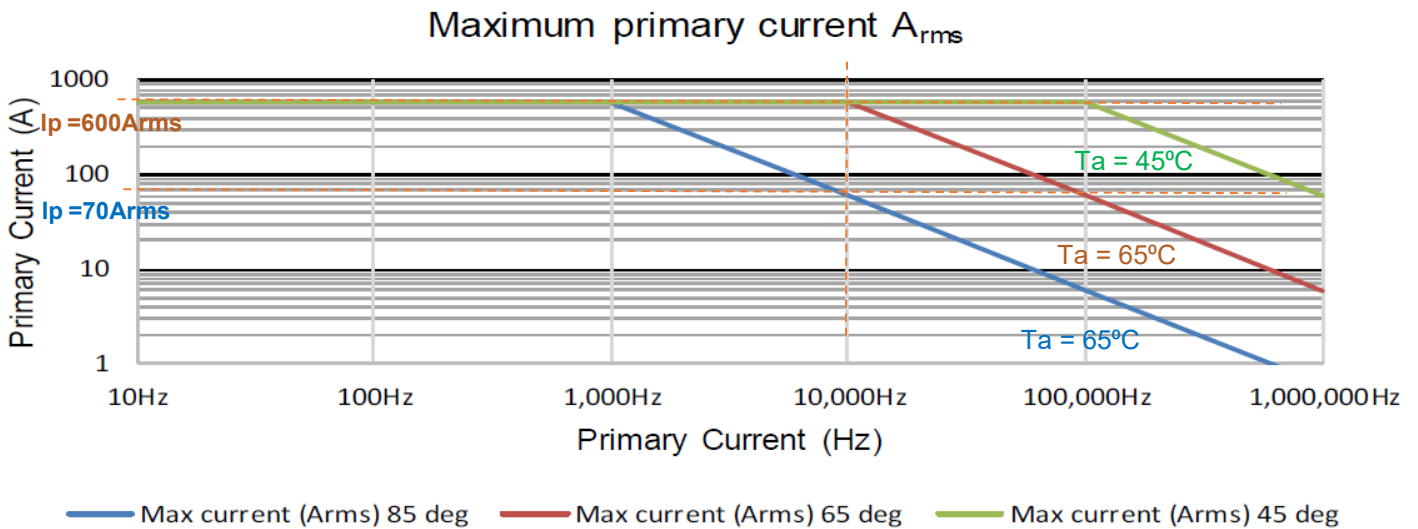

e.g. the blue curve shows that at ambient temperature $T_a = 85^\circ C$ and $f = 10kHz$, the max current measurable without overheating the current transducer is around 70Arms only. However, if $T_a = 65^\circ C$ the brown curve shows that the max current measurable at 10kHz is 600Arms.

4.7 Measuring large current with two transducers

Sometimes it is necessary to measure higher current value but how to do it. In fact by using two current output transducers in parallel as shown in the illustration below it is possible to measure accurately higher current.

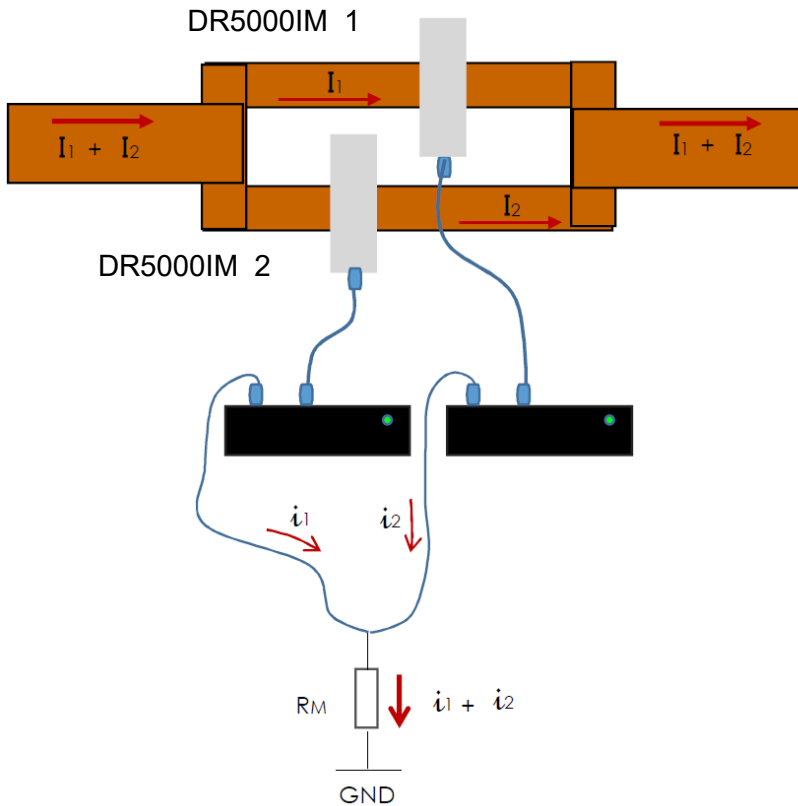

Consideration must be given to the value of the measuring resistor R_M to avoid saturation. Please consult with Danisense or your nearest local Danisense's representative for advice.

4.8 Measuring small currents with multiple primary turns

Danisense's ultra-stable and high precision fluxgate current transducers exhibit excellent linearity error (less than a few ppm), one of the best few available in the market. For instance, model DS600ID has a linearity error max of 1ppm which is $0.6\mu A$ secondary or $0.9mA$ primary. Excluding offset error, the accuracy at small primary current, e.g.: 10A will be 0.009% or 90ppm. This is very good for many applications.

However, it's possible to have better precision of measurement in the case of small primary currents by making a number of primary turns to increase the Ampere x turns (AT) value of the measured current.

e.g. : a primary cable is wound 10 times (10 turns) around the aperture of a DS600ID is equivalent to a single conductor with $10 \times 60A = 600AT$.

To achieve the best accuracy of the measurement, it's recommended to have a regular repartition of the turns around the hole to avoid unbalance (local saturation) of the magnetic core. Again, we're talking here about application that requires ppm accuracy.

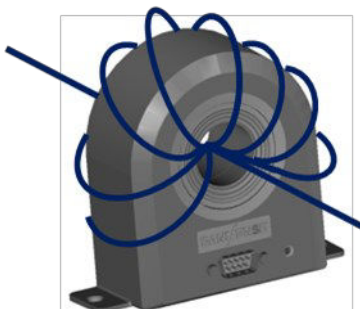

4.9 Advanced Sensor Protection Circuit (ASPC)

As shown on the first page of this Product Manual, this is a high precision electronic device containing instrument class operational amplifiers, magnetic core with windings etc. which requires special attention for handling and operating to avoid damage to the device and to prevent high induced voltage by the ACCT effect. It's highly recommended to:

- Turn **OFF** all power sources before connecting - disconnecting the device.
- Respect the **pin assignment** of the connector.
- Respect **INSULATION** class of the device
- Ensure that the device's output is **NOT** open.
- Device must be **powered and ready** (**green LED lit**) before turning ON the primary circuit.

DANISENSE's fluxgate devices are equipped with an Advance Sensor Protection Circuit to provide protection of the device during transitory period.

ASPC working principle and design is described below:

- Short-circuit the coil's terminals when power supplies are not connected or when they are OFF.
- Limit the coil's induced voltage in case the device's output is open (RM not connected)
- Protect the electronics in case of overvoltage spikes from the power supplies

CAUTION ⇒ Please observe the absolute maximum rating values specified in the individual datasheets to avoid damaging the device

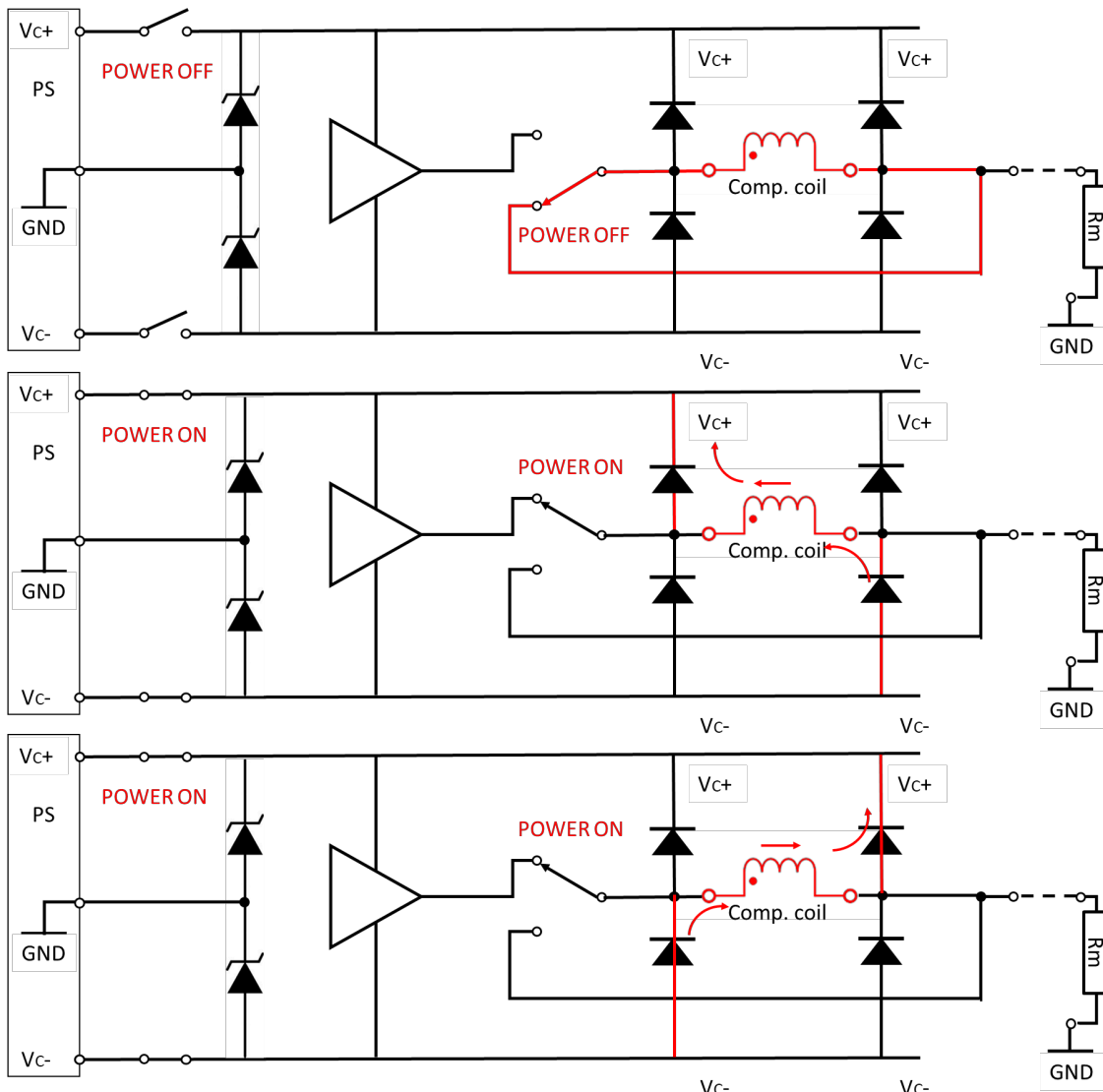

5. DEFINITION OF PARAMETERS

Parameter	Symbol	Unit	Definition
Nominal primary AC current	$I_{PN AC}$	Arms	Rated AC current for continuous operation
Nominal primary DC current	$I_{PN DC}$	A	Rated DC current for continuous operation
Measuring range	\hat{I}_{PM}	A	Max DC current (or peak value) that can be accurately measured
Overload capacity	\hat{I}_{OL}	A	Max primary current without damage. Device will be saturated during the overload period.
Nominal secondary current	I_{SN}	mA	Value of the device's output signal when a current of nominal value flows in a conductor placed inside the device's center hole
Primary / secondary ratio	$n1:n2$	none	e.g. 1:1500 means if primary current is 600A, then secondary current (device's output signal) is $600A / 1500 = 0.4A$ or 400mA
Measuring resistance	R_M	Ω	The device's output current must be "closed" to enable the flux compensation. <div style="text-align: center;"> </div>
Linearity error	ϵ_L	ppm μA	Maximum deviation or error (in ppm or in absolute μA value) between the output signal of the current transducer at any given point between 0 and $\pm \hat{I}_{PM}$ and the linear regression line obtained from a series of actual output values from $-\hat{I}_{PM}$ to $+\hat{I}_{PM}$ measured at regular current value intervals between these two extremes. <div style="text-align: center;"> </div>
Offset current (including earth field)	I_{OE}	ppm μA	Value of the device's output signal when there is no primary current in the device's center hole <div style="text-align: center;"> </div>

6. PRODUCT NAMING RULES

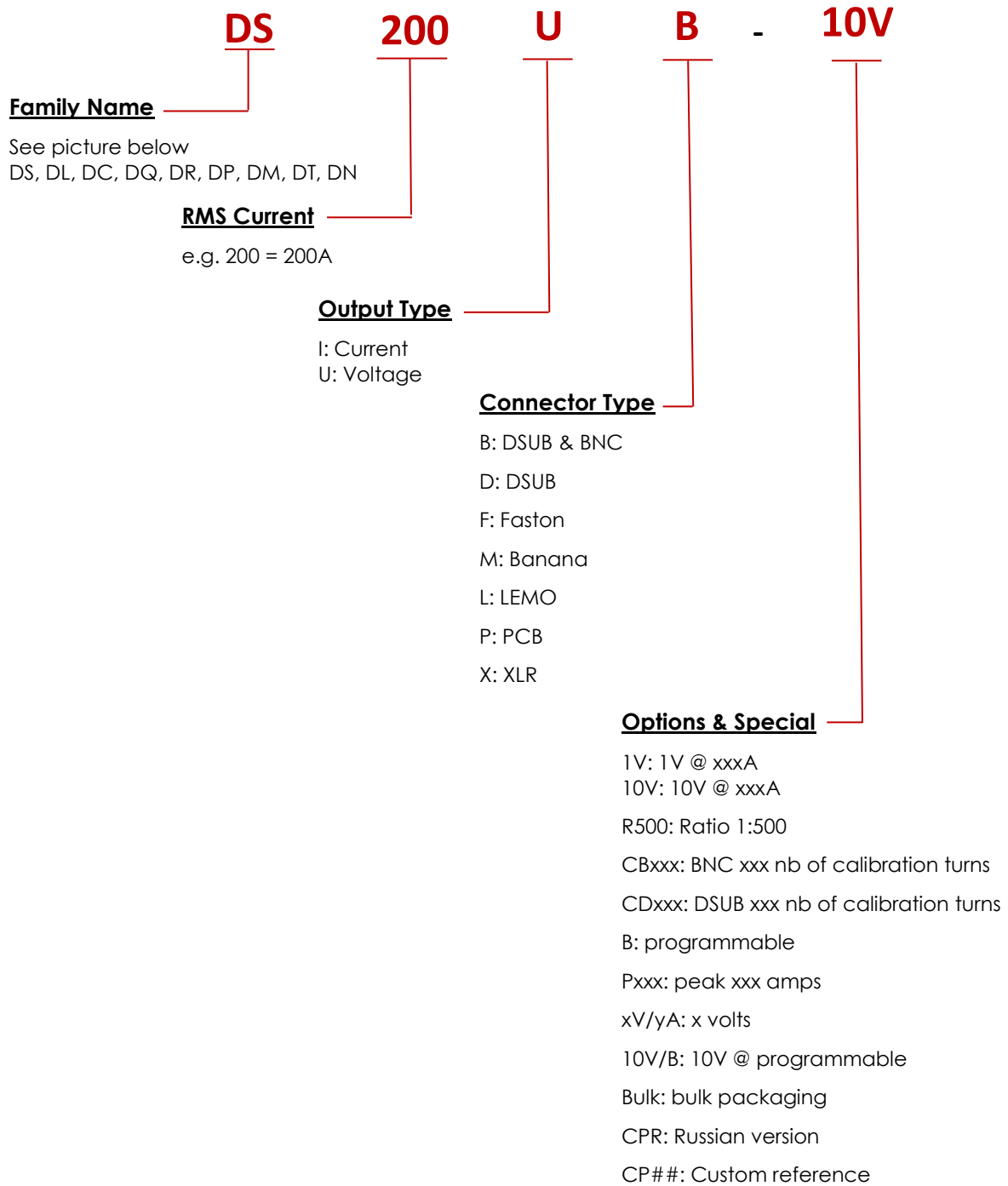

Family name description:

