

PROPRIETARY AND CONFIDENTIAL

THE INFORMATION CONTAINED IN THIS DRAWING IS THE SOLE PROPERTY OF DYTRAN INSTRUMENTS INC. ANY REPRODUCTION IN PART OR AS A WHOLE WITHOUT THE WRITTEN PERMISSION OF DYTRAN INSTRUMENTS INC. IS PROHIBITED

MODEL NO.	RANGE
7577A1	±2g
7577A2	±5g
7577A3	±10g
7577A4	±30g
7577A5	±50g
7577A6	±100g
7577A7	±200g

REVISIONS					
REV.	ECN	DESCRIPTION	BY/DATE	CHK	APPR
A	12888	INITIAL RELEASE. SAME AS REV X3.	KG 11/09/18	DP	W

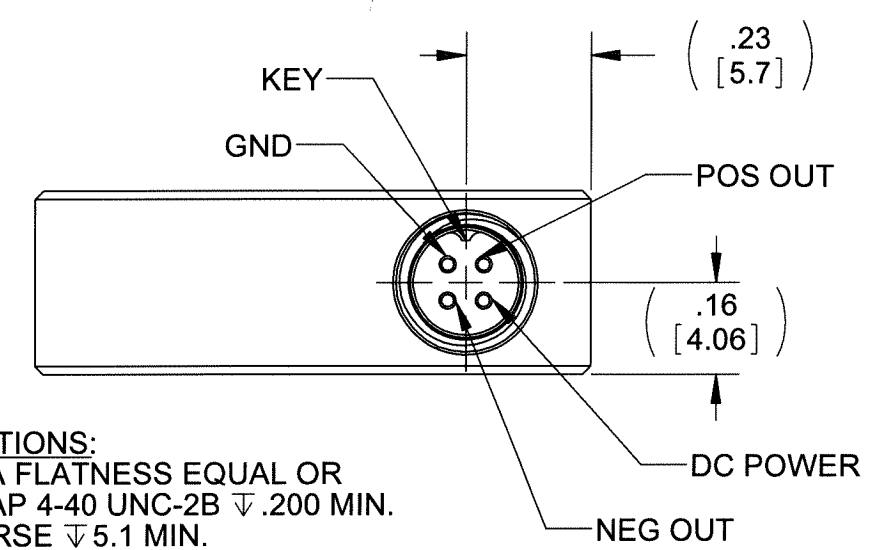
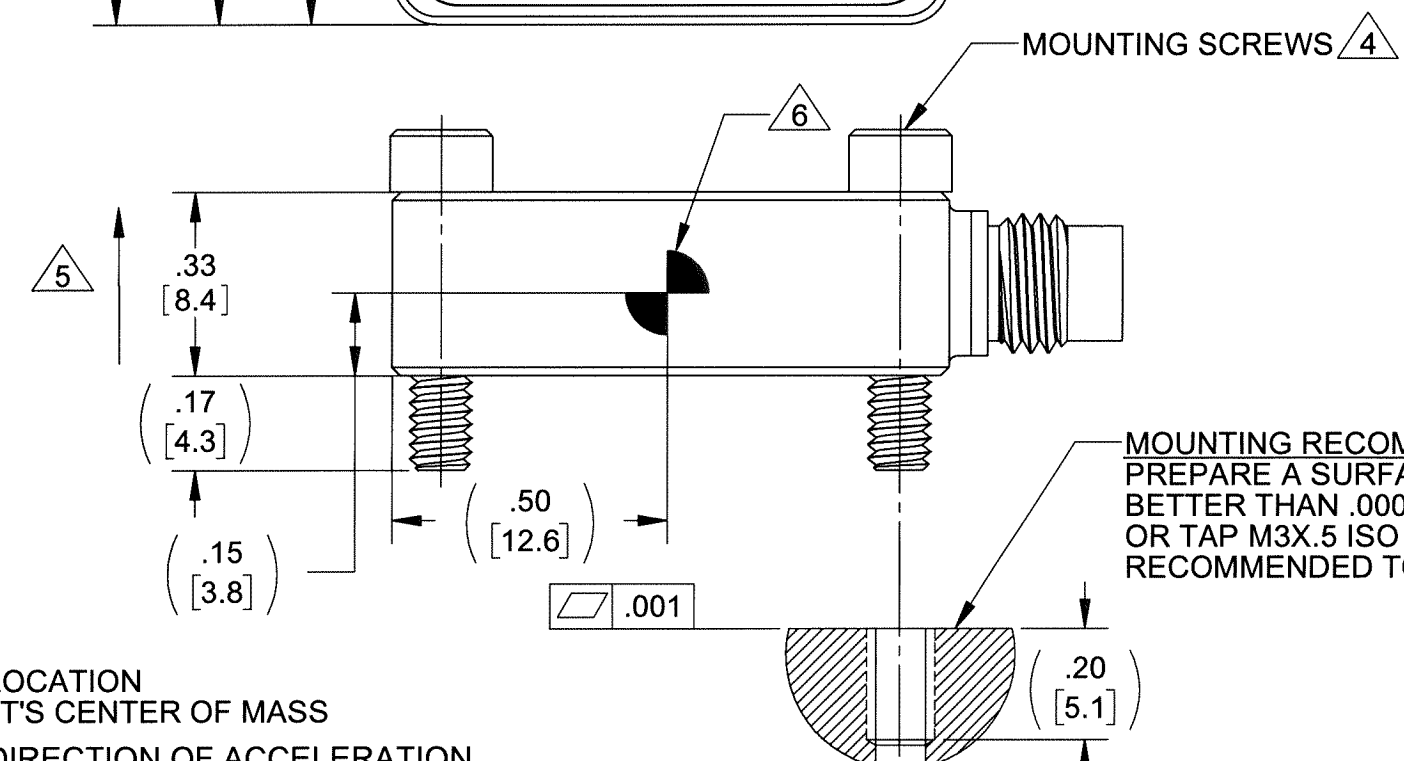
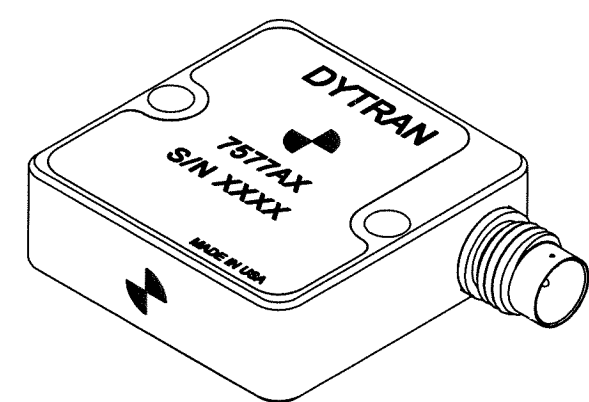
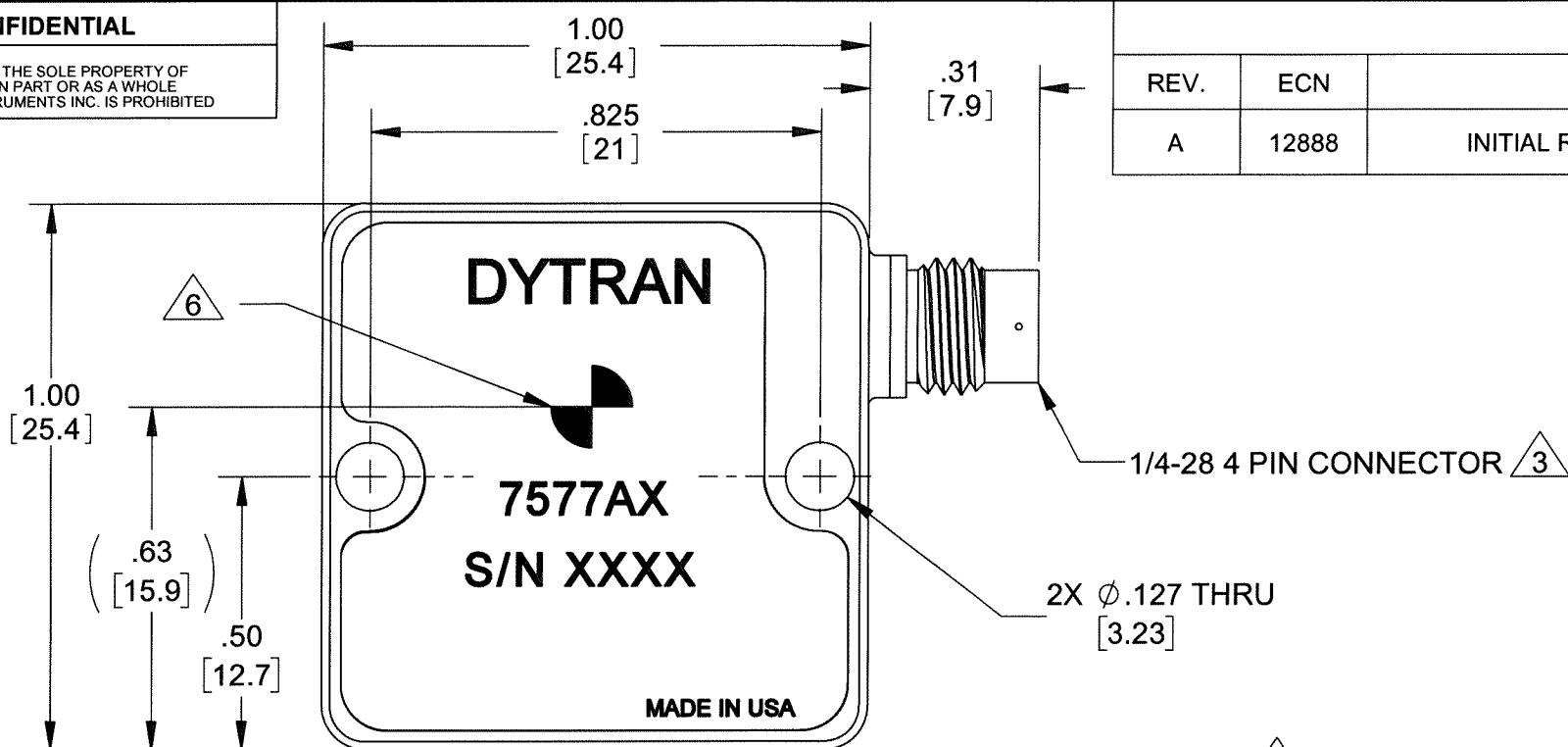

MOUNTING RECOMMENDATIONS:
 PREPARE A SURFACE TO A FLATNESS EQUAL OR BETTER THAN .0001 TIR. TAP 4-40 UNC-2B ∇.200 MIN. OR TAP M3X.5 ISO 6H COARSE ∇5.1 MIN. RECOMMENDED TORQUE 10-12 LB-IN.

- △6 MARKING DENOTES LOCATION OF SENSING ELEMENT'S CENTER OF MASS
- △5 ARROW INDICATES DIRECTION OF ACCELERATION FOR POSITIVE OUTPUT.
- △4 MOUNTING SCREWS: DYTRAN MODEL 6868 (4-40 UNC-2A) AND 6688 (M3X.5 ISO 6H COARSE), 2 EACH PROVIDED.
- △3 MATES WITH MODEL 6811AXX 4 PIN TO (3) BNC OR 6824AXX 4 PIN TO (3) BNC CABLES (XX = LENGTH IN FEET).

- 2. HOUSING/CONNECTOR MATERIAL: TITANIUM ALLOY.
- 1. WEIGHT: 17 GRAMS, MAX.

NOTES: UNLESS OTHERWISE SPECIFIED

UNLESS OTHERWISE SPECIFIED: INTERPRET DIM & TOL PER ASME Y14.5M - 1994. REMOVE BURRS. COUNTERSINK INTERNAL THDS 90° TO MAJOR DIA. CHAM EXT THDS 45° TO MINOR DIA. THD LENGTHS AND DEPTHS ARE FOR MIN FULL THDS. DIMENSIONS APPLY AFTER FINISHING.		UNLESS OTHERWISE SPECIFIED: DIMENSIONS IN BRACKETS [] ARE IN MILLIMETERS TOLERANCES ARE:		MASTER ONLY FINISHED	
DECIMALS	METRIC	ANGLES			
.XX ±.03	.X ±0.8	±1°		TITLE: OUTLINE/INSTALLATION DRAWING, VARIABLE CAPACITANCE ACCELEROMETER, MODEL 7577A	
.XXX ±.010	.XX ±0.25			SIZE B	CAGE CODE 2W033
APPROVALS		DATE		DWG NO 127-7577A	REV A
ORIG	LA	08/11/16			
CHK	DP	11/19/18			
APP	W	12/3/18			
DO NOT SCALE DRAWING		THIRD ANGLE PROJECTION		SCALE: 3:1	SHEET 1 OF 1



- **VARIABLE CAPACITANCE ACCELEROMETER**
- **DIFFERENTIAL MODE**
- **HERMETICALLY SEALED**
- **DC RESPONSE**
- **HIGH SHOCK SURVIVAL**
- **EXTENDED FREQUENCY RESPONSE**

	ENGLISH		SI	
PHYSICAL				
Weight, Max	0.60	oz	17	grams
Connector	Type 4-Pin, 1/4-28 UNF-2A		4-Pin, 1/4-28 UNF-2A	
Mounting	Thru Holes 2 X Ø.127"		2 X Ø3.23mm	
Material	Titanium Alloy		Titanium Alloy	
PERFORMANCE				
Input Range	±5	g	±49.03	m/s ²
Frequency Response (±5%)	0 - 1025	Hz	0 - 1025	Hz
Frequency Response (±3dB)	0 - 1900	Hz	0 - 1900	Hz
Resonant Frequency	>1900	Hz	>1900	Hz
Sensitivity Differential, ±10% [1]	800	mV/g	81.6	mV/m/s ²
Output Noise, Differential, Typ.	17	µg rms/√ Hz	167	µ m/s ² /√ Hz
Non-Linearity, Max.	0.5	% F.S.	0.5	% F.S.
Transverse Sensitivity, Max.	3	%	3	%
ENVIRONMENTAL				
Maximum Mechanical Shock	6000	gpk	58840	m/s ² peak
Operating Temperature Range	-67 to +257	°F	-55 to +125	°C
Scale Factor Temperature Coefficient [2]	-11 to +122	ppm/°F	-20 to +220	ppm/°C
Seal	Hermetic		Hermetic	
ELECTRICAL				
Output Common Mode Voltage	2.45 - 2.65	VDC	2.45 - 2.65	VDC
Bias Calibration Error	0.017	g	0.0017	m/s ²
Output Impedance, Nom.	1	Ω	1	Ω
Operating Voltage	+6 to +14	VDC	+6 to +14	VDC
Operating Current (AOP & AON open)	3 to 6	mA DC	3 to 6	mA DC
Power Supply Rejection Ratio	>65	dB	>65	dB
Ground Isolation	>30	MΩ	>30	MΩ
Warm Up Time	<0.5	sec	<0.5	sec
Overload Recovery	<200	µsec	<200	µsec

This family also includes:

Model	Input Range (g)	Frequency Response (Hz) (±3dB)	Sensitivity Differential, ±10% (mV/g)	Max.Shock (gpk)	Noise Differential (µg rms/√Hz)
7577A1	± 2	0-1150	2,000	6000	8
7577A3	± 10	0-3200	400	6000	34
7577A4	± 30	0-4000	133	6000	102
7577A5	± 50	0-4500	80	6000	170
7577A6	± 100	0-5000	40	6000	339
7577A7	± 200	0-7000	20	6000	678

Refer to the performance specifications of the products in this family for detailed description.

Supplied Accessories:

- 1) Accredited calibration certificate (ISO 17025)
- 2) Two mounting screws of each: Model 6688 (M3.5) and Model 6868 (4-40)

Notes:

- [1] Single ended sensitivity is half of values shown.
- [2] Over the rated temperature range.
- [3] In the interest of constant product improvement, we reserve the right to change specifications without notice. It is the customer's responsibility to validate that a particular product with the properties described in the product specification is suitable for use in a particular application. Parameters provided in datasheets and / or specifications may vary in different applications and performance may vary overtime. All operating parameters, including typical parameters, must be validated for each customer application by the customer's technical experts.

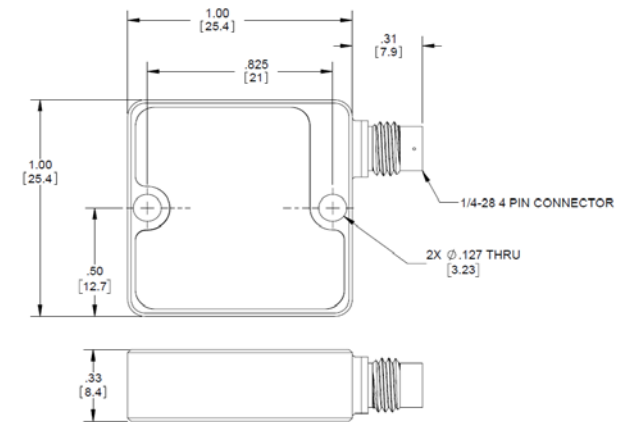
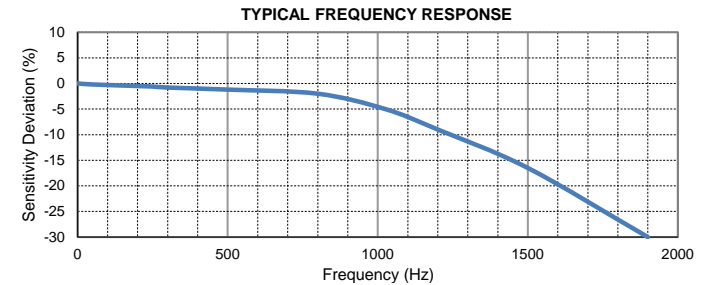

Units on the line drawing are in inches, dimensions in brackets [] are in millimeters. Refer to 127-7577A for more information.

