

PROPRIETARY AND CONFIDENTIAL

REVISIONS

THE INFORMATION CONTAINED IN THIS DRAWING IS THE SOLE PROPERTY OF DYTRAN INSTRUMENTS INC. ANY REPRODUCTION IN PART OR AS A WHOLE WITHOUT THE WRITTEN PERMISSION OF DYTRAN INSTRUMENTS INC. IS PROHIBITED

REV.	ECN	DESCRIPTION	BY/DATE	CHK	APPR
D	13677	REVISED PIN-OUT. PIN 2: AOPX(+X) WAS: AONX (-X) PIN 3: AONX(-X) WAS: AOPX (+X) PIN 4: AOPY(+Y) WAS: AONY (-Y) PIN 5: AONY(-Y) WAS: AOPY (+X) PIN 6: AOPZ(+Z) WAS: AONZ (-Z) PIN 7: AONZ(-Z) WAS: AOPY (+Z)	LN 8/17/17	MH	

MODEL	INPUT RANGE, X & Y AXES	INPUT RANGE, Z AXIS
7503D1	±2g	±2g
7503D2	±5g	±5g
7503D3	±10g	±10g
7503D4	±25g	±25g
7503D5	±50g	±50g
7503D6	±100g	±100g
7503D7	±200g	±200g
7503D8	±400g	±400g
7503D9	±5g	±25g
7503D10	±5g	±50g

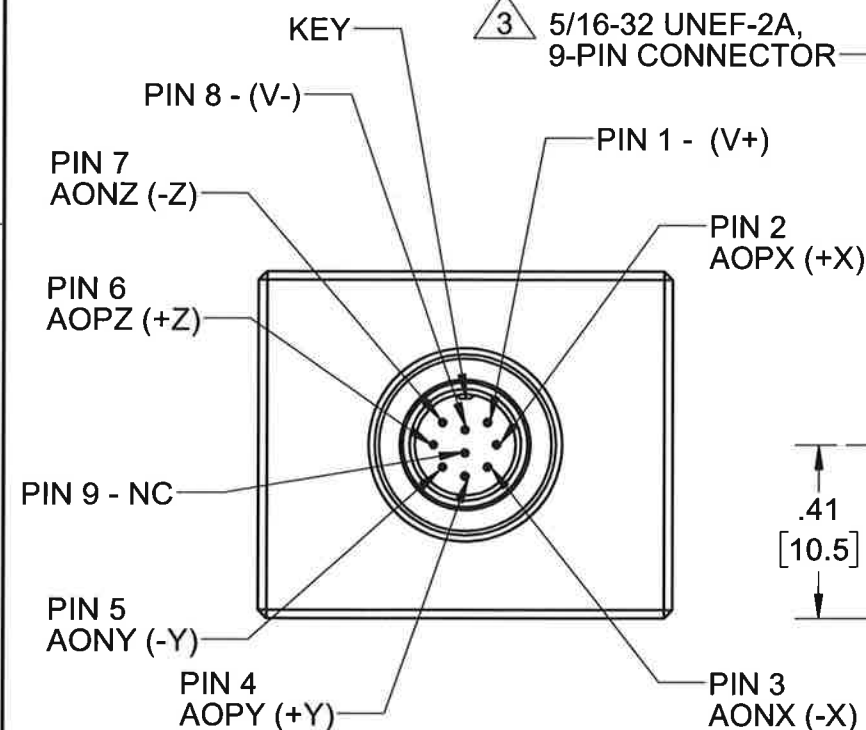
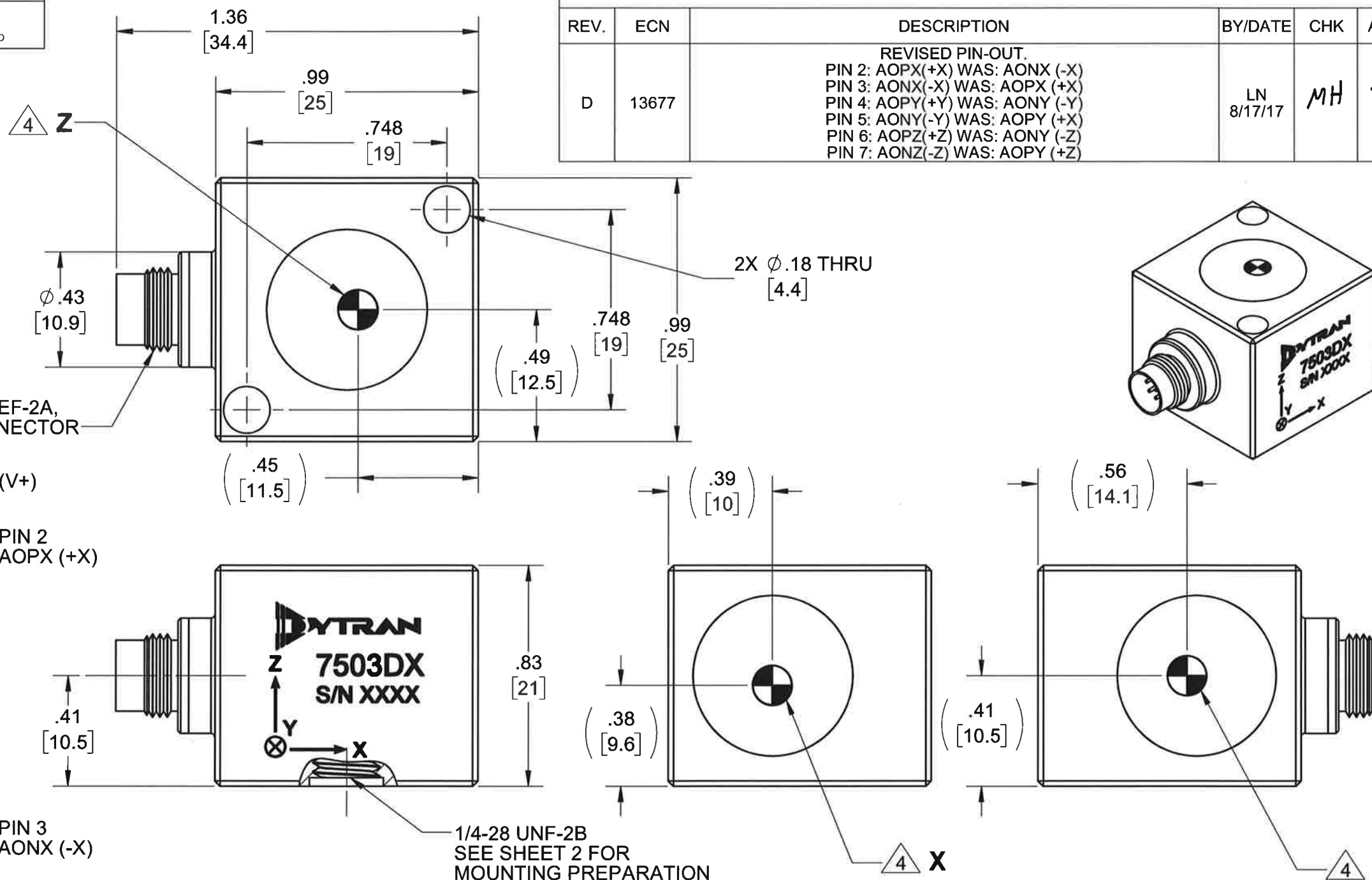

5. MINOR VOIDS, SCARS, SCRATCHES AND MOUNTING BLEMISH/WITNESS MARKS ON EXTERIOR SURFACES ARE ALLOWED DUE TO RESTRAINING AND HANDLING DURING TESTING, TRANSPORT OR PROCESSING. THESE APPEAR AS INDICATORS THAT DO NOT AFFECT FORM, FIT OR FUNCTION AS INTENDED BY DESIGN OR APPLICATION

4 MARKING DENOTES LOCATION OF SENSING ELEMENT'S CENTER OF MASS

3 MATES WITH DYTRAN 6964AXX CABLE (XX DENOTES LENGTH IN FT)

2. WEIGHT: 38 GRAMS, MAX.

1. MATERIAL: TITANIUM ALLOY.

NOTES: UNLESS OTHERWISE SPECIFIED

UNLESS OTHERWISE SPECIFIED:
INTERPRET DIM & TOL PER ASME Y14.5M - 1994.
REMOVE BURRS.
COUNTERSINK INTERNAL THDS 90° TO MAJOR DIA.
CHAM EXT THDS 45° TO MINOR DIA.
THD LENGTHS AND DEPTHS ARE FOR MIN FULL THDS.
DIMENSIONS APPLY AFTER FINISHING.

ALL MACHINED SURFACES.
TOTAL RUNOUT WITHIN .005.
BREAK SHARP EDGES .005 TO .010.
MACHINED FILLET RADII .005 TO .015.
WELDING SYMBOLS PER AWS A2.4.
ABBREVIATIONS PER MIL-STD-12.

UNLESS OTHERWISE SPECIFIED:
DIMENSIONS ARE IN INCHES.
DIMENSIONS IN BRACKETS [] ARE IN MILLIMETERS TOLERANCES ARE:

DECIMALS	METRIC	ANGLES
.XX ±.03	.X ± 0.8	±1°
.XXX ±.010	.XX ±0.25	

APPROVALS		DATE
ORIG	LN	12/01/14
CHK	JS	02/12/15
APP	DV	02/16/15
DO NOT SCALE DRAWING		THIRD ANGLE PROJECTION USA

DYTRAN MASTER
INSTRUMENTS, INC. Chatsworth, CA

TITLE: **OUTLINE/INSTALLATION DWG, TRIAXIAL DC ACCELEROMETER, 7503D SERIES**

SIZE	CAGE CODE	DWG NO	REV
B	2W033	127-7503D	D

SCALE: 1:1 SHEET 1 OF 2

PROPRIETARY AND CONFIDENTIAL

THE INFORMATION CONTAINED IN THIS DRAWING IS THE SOLE PROPERTY OF DYTRAN INSTRUMENTS INC. ANY REPRODUCTION IN PART OR AS A WHOLE WITHOUT THE WRITTEN PERMISSION OF DYTRAN INSTRUMENTS INC. IS PROHIBITED

D

D

C

C

B

B

A

A

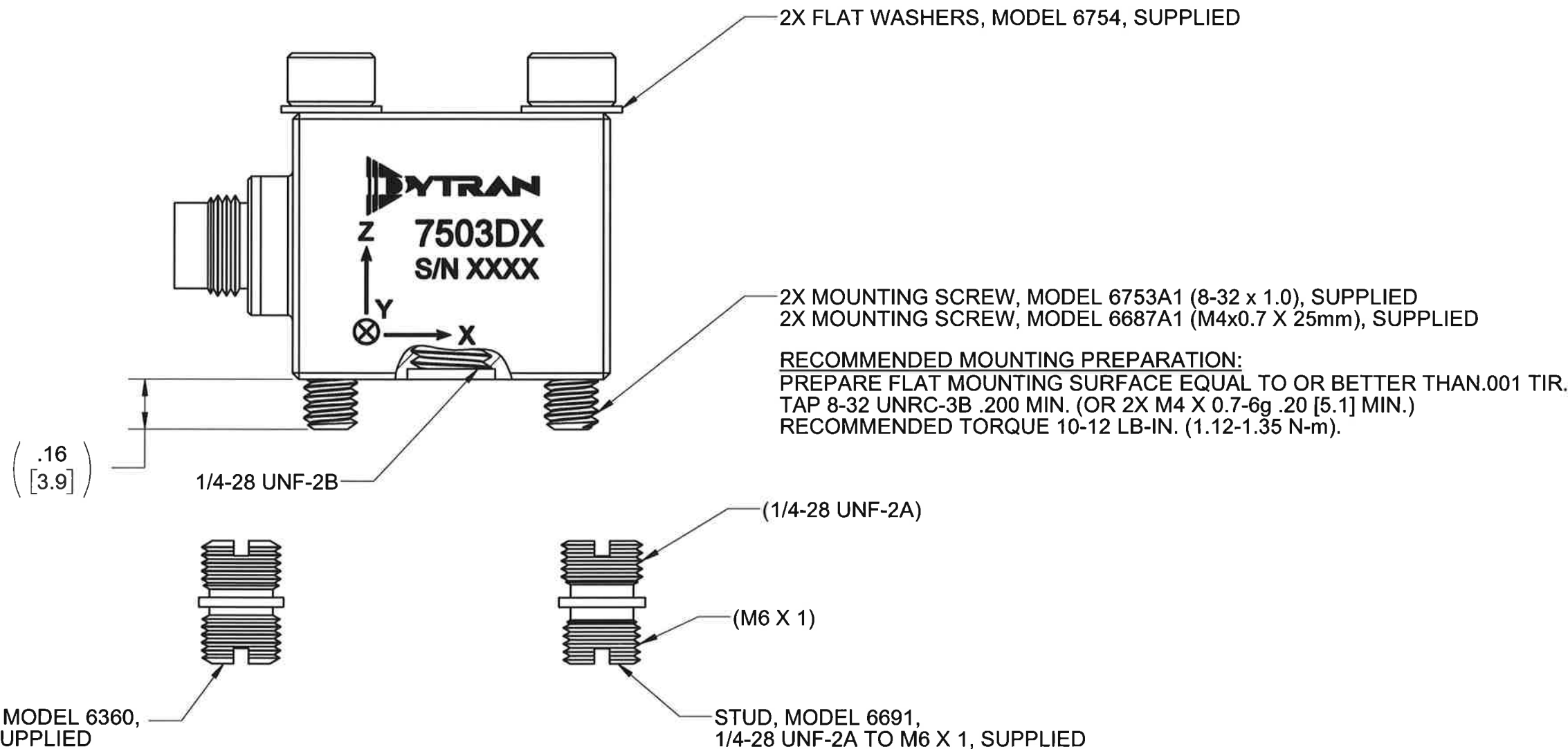

RECOMMENDED MOUNTING PREPARATION: MODEL 6360
PREPARE MOUNTING SURFACE, $\phi 1.25$ [31.2] MIN, FLAT TO .001 TIR.
TAP 1/4-28 UNF-2B $\nabla .200$ [5.1] MIN. TORQUE TO 12-15 Lb-in.

RECOMMENDED MOUNTING PREPARATION: MODEL 6691
PREPARE MOUNTING SURFACE, $\phi 1.25$ [31.2] MIN, FLAT TO .001 TIR.
TAP M6 X 1 $\nabla .200$ [5.1] MIN. TORQUE TO 12-15 Lb-in.

		MASTER	
Chatworth, CA		ONLY IF IN RED	
TITLE: OUTLINE/INSTALLATION DWG, TRIAxIAL DC ACCELEROMETER, 7503D SERIES			
SIZE B	CAGE CODE 2W033	DWG NO 127-7503D	REV D
SCALE: 2:1		SHEET 2 OF 2	

Model Number 7503D9	PERFORMANCE SPECIFICATION	DOC NO PS7503D9
TRIAxIAL VARIABLE CAPACITANCE ACCELEROMETER		REV J, ECN 15137, 06/13/19



- **VARIABLE CAPACITANCE TECHNOLOGY**
- **± 4V DIFFERENTIAL OUTPUT**
- **HERMETICALLY SEALED**
- **DC RESPONSE**

	ENGLISH		SI		
PHYSICAL					
Weight, Max	1.3	oz	38	grams	
Connector	9-pin, 5/16-32 UNEF-2A		9-pin, 5/16-32 UNEF-2A		
Material	Titanium Alloy		Titanium Alloy		
Sensing Technology	MEMS		MEMS		
PERFORMANCE					
Input Range	X & Y Axes	±5	g	±49.1	m/s ²
	Z Axis	±25	g	±196.2	m/s ²
Frequency Response (±5%)	X & Y Axes	0 - 400	Hz	0 - 400	Hz
	Z Axis	0 - 500	Hz	0 - 500	Hz
Frequency Response (±3dB)	X & Y Axes	0 - 800	Hz	0 - 800	Hz
	Z Axis	0 - 1500	Hz	0 - 1500	Hz
Resonant Frequency		>2000	Hz	>2000	Hz
Sensitivity Differential, ±5% [1]	X & Y Axes	800	mV/g	82	mV/m/s ²
	Z Axis	160	mV/g	16	mV/m/s ²
Output Noise, Differential, Typ	X & Y Axes	12	µg rms/√Hz	118	µm/s ² /√Hz
	Z Axis	44	µg rms/√Hz	432	µm/s ² /√Hz
Non-Linearity, Max [2]		0.5	% F.S	0.5	% F.S
Cross Axis Sensitivity, Max		3	%	3	%
Scale Factor Calibration Error, Max.		1	%	1	%
Zero Measured Output		±50	mV	±50	mV
ENVIRONMENTAL					
Maximum Mechanical Shock (0.1 ms)		±2000	gpk	±19620	m/s ² peak
Bias Temperature Shift, Max [3]		111	(ppm of span)/°F	200	(ppm of span)/°C
Bias Calibration Error, Max		0.5	% of span	0.5	% of span
Operating Temperature Range [4]		-67 to +257	°F	-55 to +125	°C
Scale Factor Temperature Shift [3]		-111 to +111	ppm/°F	-200 to +200	ppm/°C
Seal		Hermetic		Hermetic	
ELECTRICAL					
Output Common Mode Voltage, Typ		2.5	VDC	2.5	VDC
Output Impedance		<10K	Ω	<10K	Ω
Operating Voltage		+6 to +33	VDC	+6 to +33	VDC
Operating Current (AOP & AON open), Max		35	mA Dc	35	mA Dc
Power Supply Rejection Ratio		>65	dB	>65	dB
Ground Isolation		>30	MΩ	>30	MΩ

This family also includes:

Model	Input Range (g)	Frequency Response, ±3dB (Hz)	Sensitivity Differential, ±5% (mV/g)	Max. Shock (0.1ms) g (peak)	Noise Differential (µg/√Hz)
7503D1	±2	0-400	2,000	2000	10.5
7503D2	±5	0-800	800	2000	12
7503D3	±10	0-1000	400	2000	18
7503D4	±25	0-1500	160	2000	44
7503D5	±50	0-2700	80	2000	69
7503D6	±100	0-2500	40	2000	122
7503D7	±200	0-5000	20	2000	290
7503D8	±400	0-4000	10	2000	400
7503D10	±5(X&Y), ±50(Z)	0-800(X&Y), 0-2700(Z)	800(X&Y), 80(Z)	2000	12(X&Y), 69(Z)

Refer to the performance specifications of the products in this family for detailed description.

Supplied Accessories:

- 1) Accredited calibration certificate (ISO 17025)
- 2) Mounting stud, Model 6360, 1/4-28 UNF-2A, Qty 1
- 3) Mounting stud, Model 6691, 1/4-28 UNF-2A to M6 X 1, Qty 1
- 4) Mounting screws, Model 6753A1, 8-32 x 1.0, Qty. 2
- 5) Mounting screws, Model 6687A1, M4x0.7 x 25mm, Qty. 2
- 6) Flat washers, Model 6754, Qty. 2

Notes:

- [1] Single ended sensitivity is half of values shown. (Ref. at 100 Hz)
- [2] -90% to +90% of Full Scale.
- [3] Over the rated temperature range.
- [4] Limit operating voltage to +24VDC when temperature is greater than 240°F (115°C).
- [5] In the interest of constant product improvement, we reserve the right to change specifications without notice. It is the customer's responsibility to validate that a particular product with the properties described in the product specification is suitable for use in a particular application. Parameters provided in datasheets and / or specifications may vary in different applications and performance may vary overtime. All operating parameters, including typical parameters, must be validated for each customer application by the customer's technical experts.

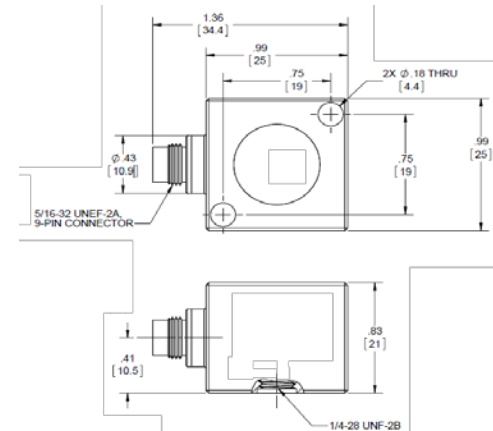

Units on the line drawing are in inches, units in brackets are in millimeters. Refer to 127-7503D for more information.



21592 Marilla Street, Chatsworth, California 91311 Phone: 818.700.7818 Fax: 818.700.7880 www.dytran.com
For permission to reprint this content, please contact info@dytran.com