

PROPRIETARY AND CONFIDENTIAL

THE INFORMATION CONTAINED IN THIS DRAWING IS THE SOLE PROPERTY OF DYTRAN INSTRUMENTS INC. ANY REPRODUCTION IN PART OR AS A WHOLE WITHOUT THE WRITTEN PERMISSION OF DYTRAN INSTRUMENTS INC. IS PROHIBITED

REVISIONS

REV.	ECN	DESCRIPTION	BY/DATE	CHK	APPR
A	11394	INITIAL RELEASE	RA, 11/06/14	EM	DV
B	11943	REVISED MARKING LOCATION, ADDED VIEW A-A	RA, 05/05/15	MH	LN
C	11983	3056D7 WAS: 5 mV/g, ADDED: 3056D8	LA, 05/28/15	DV	MH
D	14310	ZONE B3 10-32 UNF WAS: 10-32 UNC	RA, 06/28/18	MH	LD

D

D

MODEL	SENSITIVITY
3056D1	10 mV/g
3056D2	100 mV/g
3056D3	500 mV/g
3056D4	20 mV/g
3056D5	50 mV/g
3056D6	200 mV/g
3056D7	1 mV/g
3056D8	5 mV/g

C

C

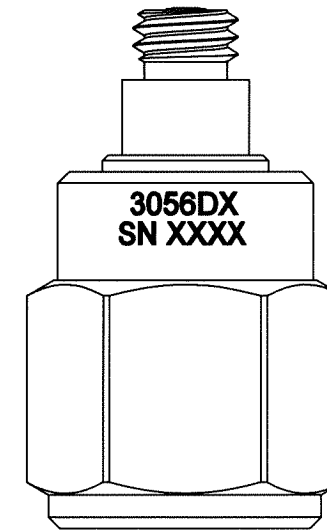
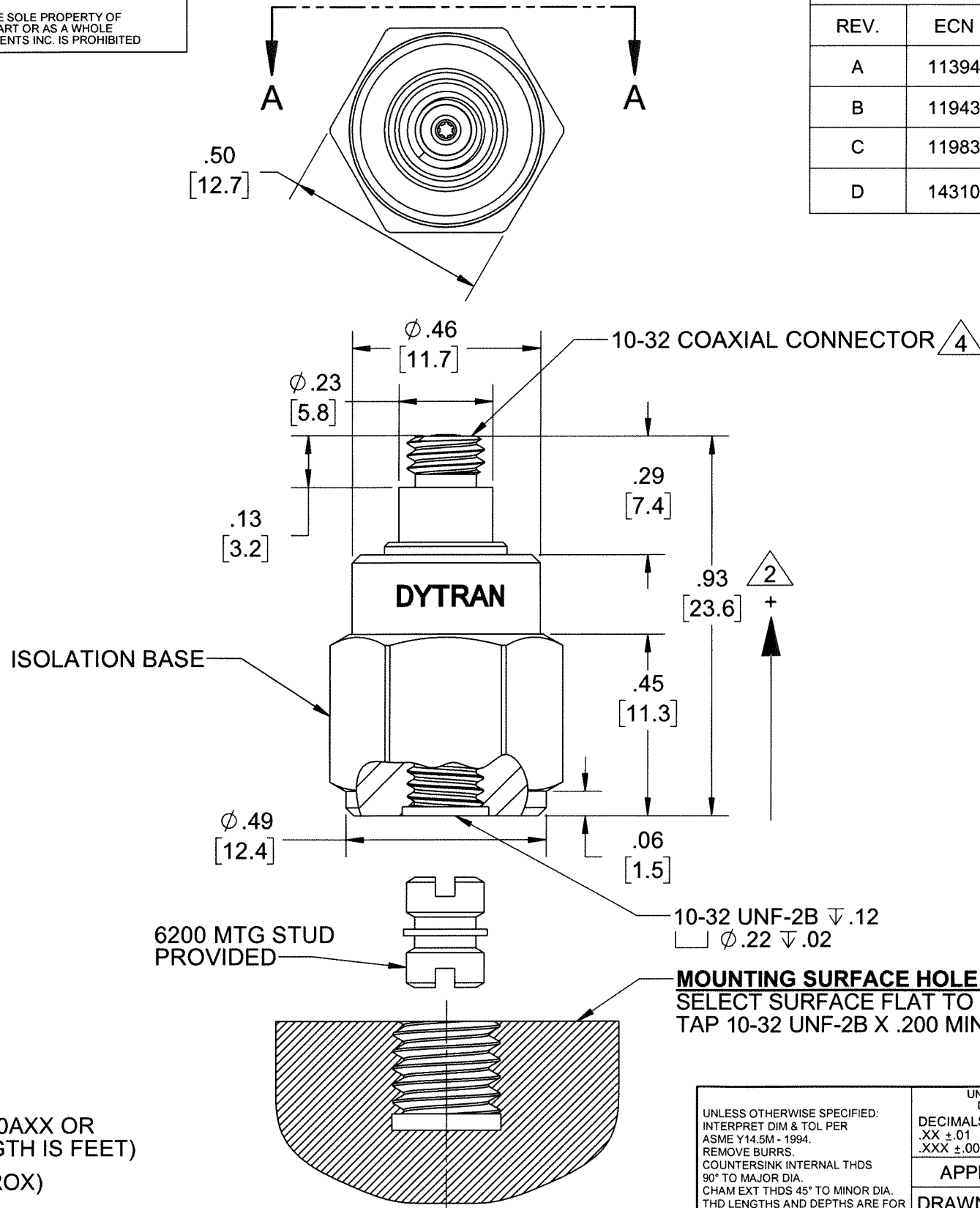

VIEW A-A
ROTATED 180°CW

B

B

4 MATES WITH DYTRAN 6010AXX OR 6011AXX CABLE (XX=LENGTH IS FEET)

3. WEIGHT: 10 GRAMS (APPROX)

2 ARROW INDICATES ACCELERATION DIRECTION FOR POSITIVE OUTPUT.

1. MATERIAL: TITANIUM ALLOY

NOTES: UNLESS OTHERWISE SPECIFIED

UNLESS OTHERWISE SPECIFIED: INTERPRET DIM & TOL PER ASME Y14.5M - 1994. REMOVE BURRS. COUNTERSINK INTERNAL THDS 90° TO MAJOR DIA. CHAM EXT THDS 45° TO MINOR DIA. THD LENGTHS AND DEPTHS ARE FOR MIN FULL THDS. DIMENSIONS APPLY AFTER FINISHING.		UNLESS OTHERWISE SPECIFIED: DIMENSIONS ARE IN INCHES. DECIMALS TOLERANCES ARE: .XX ± .01 .XXX ± .005		ANGLES ± 1°	
APPROVALS		DATE		TITLE:	
DRAWN	RA	10/29/14		OUTLINE/INSTALLATION, MODEL 3056D	
DESIGN	RT	08/28/14			
CHK	EM	12/12/14			
APP	DV	12/17/14		SIZE	B
DO NOT SCALE DRAWING		THIRD ANGLE PROJECTION		CAGE CODE	2W033
				DWG NO	127-3056D
				REV	D
				SCALE:	3:1
				PART NO:	3056D
				SHEET 1 OF	1

DYTRAN
INSTRUMENTS, INC. Chatsworth, CA

MASTER ONLY IF IN RED

SCALE: 3:1 PART NO: 3056D SHEET 1 OF 1

A

A

Model Number 3056D7	PERFORMANCE SPECIFICATIONS	DOC NO PS3056D7
IEPE ACCELEROMETER		REV J, ECN 15637, 03/17/20



- HERMETICALLY SEALED
- BASE ISOLATED

PHYSICAL

Weight
Connector
Mounting Provision
Material, Housing/Connector
Sensing Element
Element Style

ENGLISH		SI	
0.35	oz	10	grams
10-32		10-32	
10-32 X .150 ↓		10-32 X .150 ↓	
Titanium		Titanium	
Ceramic		Ceramic	
Planar Shear		Planar Shear	

PERFORMANCE

Sensitivity, ±5% [1]
Range for ± 5 Volts Output
Frequency Response, ±10%
Resonant Frequency
Broad Band Resolution
Linearity [2]
Maximum Transverse Sensitivity
Strain Sensitivity @ 250µε

1	mV/G	0.1	mV/m/s ²
5,000	G peak	49050	m/s ²
1 to 10,000	Hz	1 to 10,000	Hz
> 36	kHz	> 36	kHz
0.009	G rms	0.088	m/s ² rms
±1	% F.S.	±1	% F.S.
5	%	5	%
0.001	G/µε	0.01	m/s ² /µε

ENVIRONMENTAL

Maximum Vibration
Maximum Shock
Temperature Range
Seal

6000	G peak	58860	m/s ² peak
8000	G peak	78480	m/s ² peak
-67 to 250	°F	-55 to 121	°C
HERMETIC		HERMETIC	

ELECTRICAL

Supply Current Range [3]
Compliance Voltage Range
Output Impedance, Typ
Bias Voltage
Discharge Time Constant
Electrical Isolation

2 to 20	mA	2 to 20	mA
+18 to +30	Volts	+18 to +30	Volts
100	Ω	100	Ω
+9 to +13	VDC	+9 to +13	VDC
.5 to 1.5	Sec	.5 to 1.5	Sec
10	GΩ,min	10	GΩ,min

This family also includes:

Model	Sensitivity (mV/g)	Frequency Response (Hz)	Time Constant (Sec)	Operating Temp (°F)
3056D1	10	1 to 10000	0.5 to 1.5	-67 to +250
3056D2	100	1 to 10000	0.5 to 1.5	-67 to +250
3056D3	500	1 to 10000	0.5 to 1.5	-67 to +225
3056D4	20	1 to 10000	0.5 to 1.5	-67 to +250
3056D5	50	1 to 10000	0.5 to 1.5	-67 to +250
3056D6	200	1 to 10000	0.5 to 1.5	-67 to +225
3056D8	5	1 to 10000	0.5 to 1.5	-67 to +250

Refer to the performance specifications of the products in this family for detailed description

Supplied Accessories:

- 1) Accredited calibration certificate (ISO 17025)
- 2) Model 6200 mounting stud, QTY 1

Notes:

- [1] Measured at 100Hz, 1 Grms per ISA RP 37.2.
 - [2] Measured using zero-based straight line method, % of F.S. or any lesser range.
 - [3] Do not apply power to this system without current limiting, 20 mA MAX. To do so will destroy the IC charge amplifier.
 - [4] In the interest of constant product improvement, we reserve the right to change specifications without notice.
- It is the customer's responsibility to validate that a particular product with the properties described in the product specification is suitable for use in a particular application. Parameters provided in datasheets and / or specifications may vary in different applications and performance may vary overtime. All operating parameters, including typical parameters, must be validated for each customer application by the customer's technical experts.

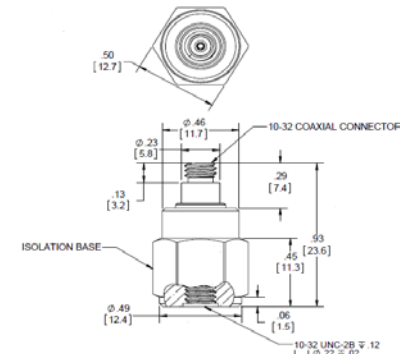
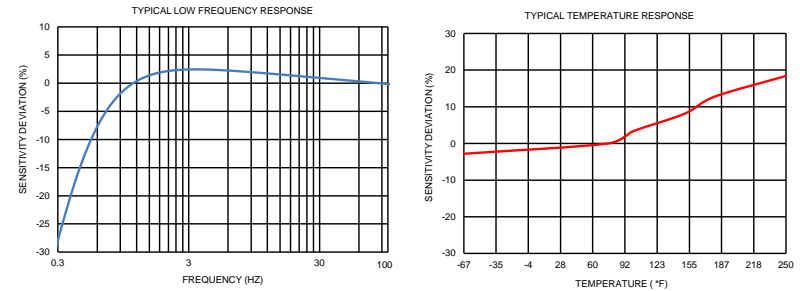

Units on the line drawing are in inches, units in brackets are in millimeters. Refer to 127-3056D for more information.

