

PROPRIETARY AND CONFIDENTIAL

THE INFORMATION CONTAINED IN THIS DRAWING IS THE SOLE PROPERTY OF DYTRAN INSTRUMENTS INC. ANY REPRODUCTION IN PART OR AS A WHOLE WITHOUT THE WRITTEN PERMISSION OF DYTRAN INSTRUMENTS INC. IS PROHIBITED

MODEL	SENSITIVITY mV/psi	RANGE psi
2300V1	20	250
2300V3	10	500
2300V4	5	1,000
2300V5	1	5,000
2300V6	0.5	10,000
2300V7	0.33	15,000
2300V8	2.5	2,000

REVISIONS

REV.	ECN	DESCRIPTION	BY/DATE	CHK	APPR
B	9202	CONVERTED FROM ASHLAR TO SOLIDWORKS	AB 10/01/12	JS	DV
C	9256	ADDED DIMENSIONS: ZONE C2 .03, .24, AND .25	AB 10/10/12	JS	DV
D	12651	ADDED NOTE 3, TABULATION CHART	RA, 04/28/16	MH	LN

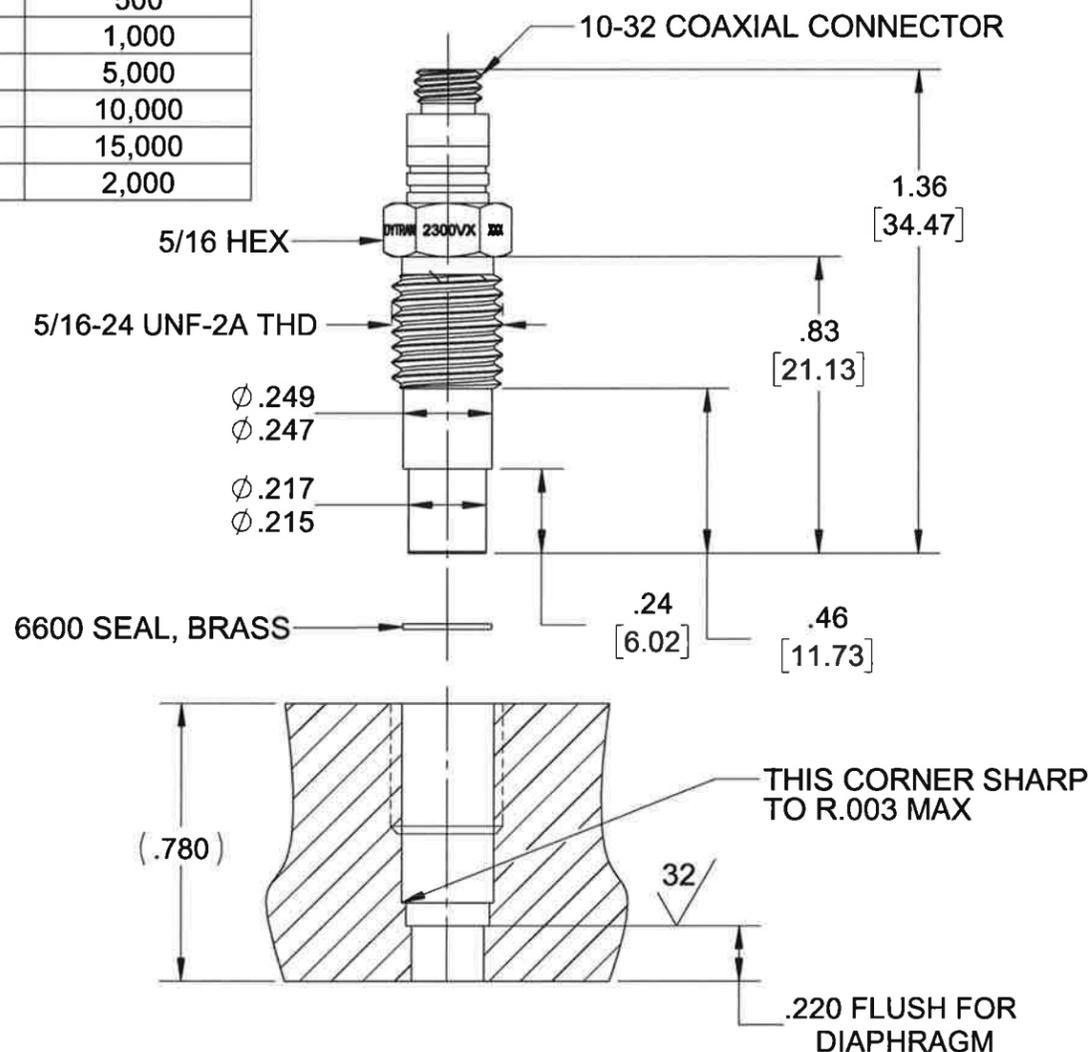

PORT PREPARATION INSTRUCTIONS, 2300V

1. DRILL AND REAM $\phi .221 +.001/.000$ THRU
2. $\square \phi .250 +.003/-.000 \times .560 \nabla$
3. DRILL $\phi .272 +.003/-.000 \times .500 \nabla$
4. BOTTOM TAP 5/16-24 UNF-2B X .440 MIN DEPTH

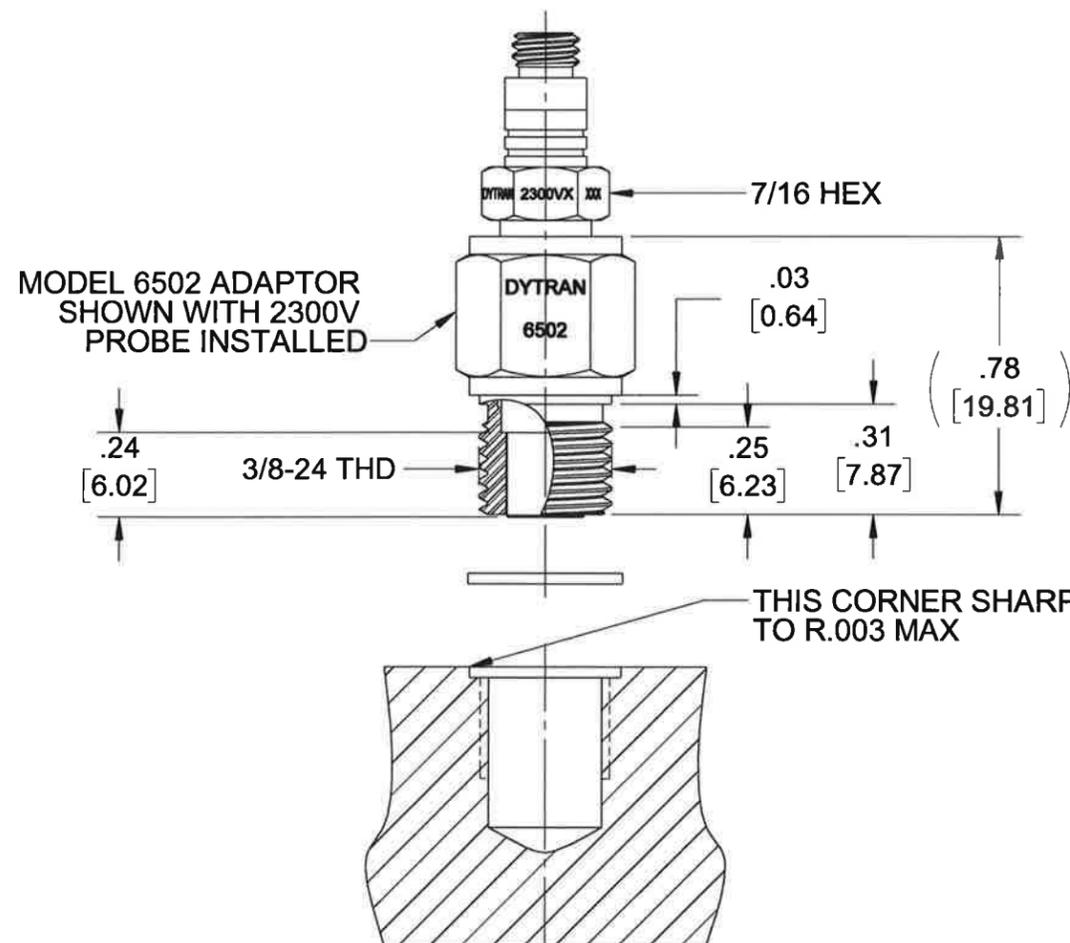

PORT PREPARATION INSTRUCTIONS, 6502

1. DRILL $\phi .332$ THRU (OR .450 MIN DEPTH)
2. TAP 3/8-24 UNF-2B X .350 MIN ∇
3. $\square \phi .437 +.003/-.000 \times .030 \nabla$

3. MINOR VOIDS, SCARS, SCRATCHES AND MOUNTING BLEMISH/WITNESS MARKS ON EXTERIOR SURFACES ARE ALLOWED DUE TO RESTRAINING AND HANDLING DURING TESTING, TRANSPORT OR PROCESSING. THESE APPEAR AS INDICATORS THAT DO NOT AFFECT FORM, FIT OR FUNCTION AS INTENDED BY DESIGN OR APPLICATION

2. MOUNTING TORQUE FOR 6502 ADAPTOR: 50-60 LB-INCHES.

1. MOUNTING TORQUE FOR 2300V PROBE: 30 LB-INCHES.

NOTES: UNLESS OTHERWISE SPECIFIED

UNLESS OTHERWISE SPECIFIED:
INTERPRET DIM & TOL PER ASME Y14.5M - 1994.
REMOVE BURRS.
COUNTERSINK INTERNAL THDS 90° TO MAJOR DIA.
CHAM EXT THDS 45° TO MINOR DIA.
THD LENGTHS AND DEPTHS ARE FOR MIN FULL THDS.
DIMENSIONS APPLY AFTER FINISHING.

ALL MACHINED SURFACES.
TOTAL RUNOUT WITHIN .005.
BREAK SHARP EDGES .005 TO .010.
MACHINED FILLET RADII .005 TO .015.
WELDING SYMBOLS PER AWS A2.4.
ABBREVIATIONS PER MIL-STD-12.

UNLESS OTHERWISE SPECIFIED:
DIMENSIONS ARE IN INCHES.
DIMENSIONS IN BRACKETS [] ARE IN MILLIMETERS TOLERANCES ARE:

DECIMALS	METRIC	ANGLES
.XX ±.03	.X ± 0.8	±1°
.XXX ±.010	.XX ±0.25	

APPROVALS		DATE
ORIG	AB	10/03/12
CHK	JS	10/12
APP	DV	10/12

DO NOT SCALE DRAWING



TITLE: **OUTLINE/INSTALLATION DRAWING, MODEL 2300V**

SIZE **B** CAGE CODE **2W033** DWG NO **127-2300V** REV **D**

SCALE: 4:1 SHEET 1 OF 1

MODEL NUMBER 2300V7	PERFORMANCE SPECIFICATION	DOC NO. PS2300V7
--------------------------------------	----------------------------------	-----------------------------------

DYNAMIC PRESSURE SENSOR, IEPE

REV A, ECN 12998, 10/12/16



- **HIGH FREQUENCY**
- **ULTRA FAST RISE TIME**
- **HERMETIC**

PHYSICAL

Weight, Max.
Mounting Provision
Connector
Material (Housing/Diaphragm)

	ENGLISH		SI	
Weight, Max.	0.2	oz	7	grams
Mounting Provision	5/16-24 UNF-2A		5/16-24 UNF-2A	
Connector	10-32 COAXIAL	Type	10-32 COAXIAL	
Material (Housing/Diaphragm)	17-4ph / 316L	Material	17-4ph / 316L	

PERFORMANCE

Sensitivity +/- 20%
Range F.S for +/- 5 volts peak out
Maximum Pressure [2]
Equivalent Electrical Noise (Resolution)
Mounted Resonant Frequency, Nom.
Minimum Rise Time of Input Pulse
Discharge Time Constant
Linearity [3]
Lower -3db Frequency
Acceleration Sensitivity, Axial Direction

Sensitivity +/- 20%	0.33	mV/psi	4.8E-05	mV/Pa
Range F.S for +/- 5 volts peak out	15000	psi	1.0E+08	Pa
Maximum Pressure [2]	18000	psi	1.2E+08	Pa
Equivalent Electrical Noise (Resolution)	0.21	psi	1447.9	Pa
Mounted Resonant Frequency, Nom.	500	kHz	500	kHz
Minimum Rise Time of Input Pulse	1	µsec	1	µsec
Discharge Time Constant	>5	sec	>5	sec
Linearity [3]	+/-1	Hz	+/-1	% F.S
Lower -3db Frequency	0.03	Hz	0.03	Hz
Acceleration Sensitivity, Axial Direction	0.001	psi/g	6.9E-03	Kpa/g

ENVIRONMENTAL

Maximum Vibration, +/-
Maximum Shock, +/-
Temperature Range [4]
Environmental Seal (Welded, Glass to Metal)
Ground Isolation, Min

Maximum Vibration, +/-	5000	g rms	49050	m/s ² rms
Maximum Shock, +/-	10000	g pk	98100	m/s ² peak
Temperature Range [4]	-100 to +250	°F	-73 to +121	°C
Environmental Seal (Welded, Glass to Metal)	Hermetic		Hermetic	
Ground Isolation, Min	100	MΩ	100	MΩ

ELECTRICAL

Compliance (Supply) Voltage Range [5]
Supply Current Range
Output Impedance, Nom.
Output Bias Voltage

Compliance (Supply) Voltage Range [5]	+18 to +30	VDC	+18 to +30	VDC
Supply Current Range	2 to 20	mA	2 to 20	mA
Output Impedance, Nom.	100	Ω	100	Ω
Output Bias Voltage	+7.5 to +9.5	VDC	+7.5 to +9.5	VDC

This family also includes:

Model	Sensitivity (mV/psi)	Range (psi pk)	Resolution (Grms)	Oper. Temp(°F)	TC (Sec)
2300V1	20 (±15%)	250	0.004	-100 to +250	>2.0
2300V3	10 (±15%)	500	0.007	-100 to +250	>5.0
2300V4	5 (±20%)	1000	0.014	-100 to +250	>10.0
2300V5	1 (±20%)	5000	0.07	-100 to +250	>50.0
2300V6	0.5 (±20%)	10000	0.14	-100 to +250	>100.0

Refer to the performance specifications of the products in this family for detailed description.

Notes:

- [1] A calibration certificate traceable to NIST is supplied with each instrument.
- [2] Refers to maximum pressure before possibility of damage to internal electronics.
- [3] Percent full scale, zero based fit straight line method.
- [4] Maximum flash temperature +3000°F (+1649°C), short duration.
- [5] From current limiting IEPE power unit only. Do not power up without current limiting power unit.
- [6] In the interest of constant product improvement, we reserve the right to change the specification without notice

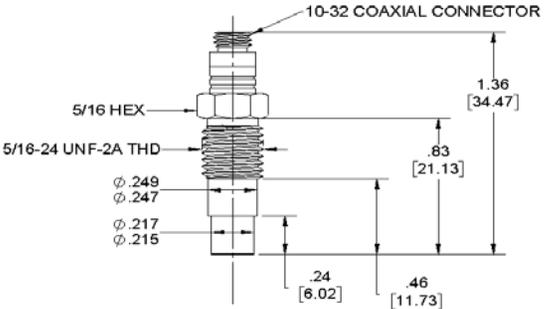
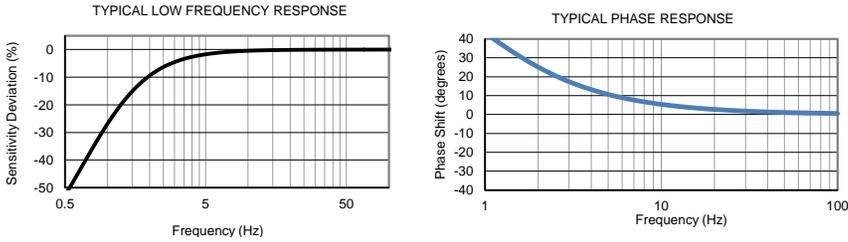

Units on the line drawing are in inches, units in brackets are in millimeters. Refer to 127-2300V for more information.



21592 Marilla Street, Chatsworth, California 91311 Phone: 818.700.7818 Fax:818.700.7880
www.dytran.com For permission to reprint this content, please contact info@dytran.com